



esa

Herschel

Document No. : PT-03646

Issue/Rev. No. : Issue 1.2

Date : 17/03/03

Page : i

Herschel Science Implementation Requirements Document

SIRD

Herschel / Planck Project

Name		Signature
Prepared by	L. Aloy Ground Segment and Operations Engineer. ESA/ESTEC/SCI-PT	 17-03-2003
Agreed by	G. L. Pilbratt Herschel Project Scientist ESA/ESTEC/SCI-SA	 17/03/2003
Approved by	T. Paßvogel Herschel/Planck Project Manager ESA/ESTEC/SCI-PT	 11/7/03
Concurred by	T. de Graauw HIFI PI SRON	 12/06/2003
Concurred by	A. Poglitsch PACS PI MPE	
Concurred by	M. Griffin SPIRE PI CARDIFF UNIVERSITY	 9 July 2003

DISTRIBUTION LIST

RECIPIENT	AFFILIATION	# of Copies
<u>Herschel Project Team</u>		
M. Anderegg	ESA/ESTEC/SCI-PT	1
P. Estaria	ESA/ESTEC/SCI-PT	3
L. Aloy	ESA/ESTEC/SCI-PT	1
A. Heske	ESA/ESTEC/SCI-PT	1
M. von Hoegen	ESA/ESTEC/SCI-PT	1
T. Passvogel	ESA/ESTEC/SCI-PT	1
Project file	ESA/ESTEC/SCI-PT	5
M. Kessler	ESA/ESTEC/SCI-SD	1
G. Pilbratt	ESA/ESTEC/SCI-SA	2
J. Riedinger	ESA/ESTEC/SCI-SDH	1
J. Clavel	ESA/ESTEC/SCI-SA	1
T. de Graauw	SRON Groningen	1
P. Roelfsema	SRON Groningen	1
C. Wafelbakker	SRON Utrecht	1
O. Bauer	MPE Garching	1
A. Poglitsch	MPE Garching	1
M. Griffin	QMWC	1
S. Guest	RAL	1
K. King	RAL	1
J. Dodsworth	ESA/ESOC/TOS-OFC	2
N. Peccia	ESA/ESOC/TOS-GCM	1
A. Smith	ESA/ESOC/TOS-OF	1



Herschel

Document No. : PT-03646
Issue/Rev. No. : Issue 1.2
Date : 17-Mar-03
Page : iii

DOCUMENT REVISION STATUS

Revision	Revision Date
1st Draft	30 November 1996
2nd Draft	31 July 1997
3rd Draft	30 September 1997
Issue 1.0	30 November 2000
Issue 1.1	18 May 2001
Issue 1.2	17 March 2003

DOCUMENT CHANGE RECORD

Revision Status			Pages affected
Rev	Date	Approval	
Draft 1	30.11.96		All (First Working Draft) for discussion within ESA and the FIRST Science Operations Definition Group (FSODG)
Draft 2	31.07.97		All changes to Draft 1 are indicated by a vertical bar in the margin. Affected pages: all
Draft 3	30.09.97		Updated after SCI-SA Rolling Review Board meeting of 16.09.97. Major changes: Document has been restructured. Chapter 1-3 and 7 now for background only. Responsibilities of PST and FOT clarified. FSCOM role redefined. Requirements have been renumbered. Several minor clarifications added to the text. Figures 7.1 and 7.5 updated. Affected pages: all
Issue 1.0	30.11.00		Affected pages: all. Major changes: Baseline changed from "merger" to "carrier". Acronym list expanded. List of Applicable and Reference documents updated. Documentation tree updated. Milestone dates brought in line with current planning. Project responsibilities updated as per F/P Project Manager – Head of SCI-SA meeting of 17.11.2000. Overall document brought in line with GS definition work carried out via the FGSSE WG. (e.g. introduction of FCSS, FINDAS work, QLA separated from RTA, ICC@MOC and ICC@ICC , QCP, on-the-fly processing, standard products generation, etc.) Separation of the tasks of the FSCDM and FSCOM. Performance and availability requirements updated. PA/QA requirements updated. Management Requirements updated. Comments from FSCDT, ESOC and PACS included.
Issue 1.1	18.05.01		Affected pages: all.

Revision Status			Pages affected
Rev	Date	Approval	
			<p>The following changes were made <u>without change bars</u>:</p> <ul style="list-style-type: none"> – Homogenisation of document layout – Nomenclature change: FIRST ⇔ Herschel, including acronyms – Correction of typos <p>Major changes <u>with change bars</u>:</p> <ul style="list-style-type: none"> – Incorporated changes as proposed in the HCSS SRR/v0.1 PDR Review Board report – Incorporated changes as agreed by the CCB which was invoked on 20-Feb-2001 as a result of the HCSS SRR/v0.1 PDR review – Incorporated HSCDT comments (JRR e-mail dd. 6-Dec-2000) – Incorporated two sets of HIFI comments (PRR e-mails dd. 8 & 9-Mar-2001) – Incorporated PACS comments (OHB e-mail dd. 8-Mar-2001) – Incorporated SPIRE comments (KJK e-mail dd. 15-Mar-2001) – Incorporated changes agreed by the HGSSE (FIRST/FSC/MOM/0171) – Incorporated latest thoughts on instrument operations – Removed many (but not all) TBDs/TBCs that did not appear to be necessary or qualified TBDs/TBCs by attributing resolution to a particular party or document or providing a deadline by when an issue is to be resolved – Incorporated PST comments – Included the results of HCSSMG telecon #22 (FIRST/FSC/MOM/0189) into the red-lined document to be returned to SCI-PT

Revision Status			Pages affected
Rev	Date	Approval	
			<p><u>Significant clarifications of requirements:</u></p> <ul style="list-style-type: none"> – ICCF-070: Added standard calibration observations – ICCF-085: Updated for compliance with SCOS 2000 use by instruments – ICCF-105: Indicated the possible existence of different time estimators for the two phases of proposal submission – ICCF-130: Clarified role of RTA, QLA and IA – ICCO-070: Elaborated on types of quality checks to be performed on mission products – FSCF-170: Replaced/clarified as FSCF-171 – FSCF-210: Expanded into three distinct requirements (FSCF-210, -220, -230) for clarification and tracking – FSCO-067: Expanded into three distinct requirements (FSCO-067, -068, 069) for clarification and tracking <p><u>Deleted or moved requirements:</u></p> <ul style="list-style-type: none"> – ICCF-110: Subsumed under clarified ICCF-085 – ICCF-146: There is no substantiated argument that key programmes will require any special processing software – ICCF-152: Subsumed under the notes to ICCF-150 – ICCA-010 & -015: Moved to ICCF-210 & -215 as this is already required during operations – PERF-012 – PERF-061 – PAQA-003 <p><u>New requirements</u></p>

Revision Status			Pages affected
Rev	Date	Approval	
			<ul style="list-style-type: none"> – ICCF-153: Added a requirement on provision of an instrument simulator capable of delivering "realistic" science data contents – ICCO-027: Extends ICCF-085 into operations – ICCO-042: Focal plane geometry determination made an explicit requirement – ICCO-090: Expanded ICCA-020 into operations – ICCA-055: For the archiving phase added support to documentation concerning instrument calibration & characterisation – FSCF-152: Explicit requirement on HSCDT to provide the pre-launch list of SSOs to MOC
Issue 1.2	09.03.03		<p>Updated after SGSR meeting of 14/15.11.02</p> <ul style="list-style-type: none"> - A new Cover Page with a new Signature Table has been implemented to keep consistency among H/P documents approval policy. The Distribution List has been updated accordingly. - A new op Level Documentation Tree has been included, following the general H/P documentation tree as presented in the SCI-PT-016463 H/P Ground Segment Documentation Plan Document. - Cited document included in the Reference Docs section as AD15. - Science Management Plan and Operations Scenario Documents have been redefined as "Source Documents" SD1 and SD2 respectively. - The Major Project Milestones in section 1.5 have been updated. - ICCF-150, -151 and -153 have been re-written to reflect the new situation

Revision Status			Pages affected
Rev	Date	Approval	
			<p>of the Instrument S/W Simulators (developed by MOC).</p> <ul style="list-style-type: none"> - According to the RIDs presented by the Herschel Calibration Steering Group (HcalSG), the following modifications have been introduced: <ul style="list-style-type: none"> o ICCF-145 rephrased. o ICCF-146, -147, -148 added. o ICCO-072 added. o ICCA-055 rephrased. o FSCF-060 modified. o FSCF-062 added. o FSCF-065 rephrased. o FSCF-075, -085 modified. o FSCF-087 added.

TABLE OF CONTENTS

CHAPTER	CHAPTER TITLE
i	Title Page
ii	Distribution List
iii	Document Revision Status
iv-vii	Document Change Record
viii	Table of Contents
ix - xii	List of Acronyms
1	Introduction
2	Assumptions
3	Responsibilities
4	Instrument Control Centre: Delegated Tasks
5	Herschel Science Centre: Delegated Tasks
6	Performance and Availability Requirements
7	Phasing and Organisation
8	Product Assurance and Quality Assurance Requirements
9	Management Requirements

ACRONYM LIST

*It is assumed that an overall **Herschel** acronym list will be available at a later time. The present list therefore only contains the acronyms which are used in the context of this document*

AIV	Assembly Integration Verification
AMS	Archive Management System
AND	Alphanumeric Display
APID	Application Identifier
AO	Announcement of Opportunity
AOCS	Attitude & Orbit Control System
AOS	Acquisition of Signal
AOT	Astronomical Observation Template
APH	Attitude Pointing History
AVM	Avionics Model
AWG	(ESA) Astronomy Working Group
CC	Configuration Control
CCS	Central Command Schedule
CDMS	Command and Data Management System
C/O	Check-Out
Co-I	Co-Investigator
Co-PI	Co-Principal Investigator
CQM	Cryogenic Qualification Model
CRP	Contingency Recovery Procedure
CRR	Customer Requirements Review
CS4	Cornerstone 4 (in Horizon 2000, i.e. Herschel)
CUS	Common Uplink System
Dec	Declination
DPU	Data Processing Unit
D/SCI	(ESA) Director of Scientific Programmes
EGSE	Electrical Ground Support Equipment
EMC	Electro-magnetic Compatibility
EMI	Electro-magnetic Interference
ESD	Electro-static Discharge
ESA	European Space Agency
ESOC	(ESA) Space Operations Centre
FCP	Flight Control Procedure
FD	Flight Dynamics
FM	Flight Model
FOP	Flight Operations Plan
FOV	Field Of View
FTP	File Transfer Protocol

GO	Guest Observer
GRD	Graphic Display
GS	Ground Segment
GSDR	Ground Segment Design Review
GSIR	Ground Segment Implementation Review
GSM	(ESOC) Ground Segment Manager
GSRQR	Ground Segment Requirements Review
GSRR	Ground Segment Readiness Review
GTO	Guaranteed Time Observer
GUI	Graphical User Interface
Gb	GigaBit
HIFI	Heterodyne Instrument fro the Far Infrared
HCSS	Herschel Common Science System
HCSSMG	Herschel Management Group
H-GSAG	Herschel Ground Segment Advisory Group
HK	Housekeeping
HOTAC	Herschel Observing Time Allocation Committee
H/P OIRD	Herschel/Planck Operations Interface Requirements Document
HSC	Herschel Science Centre
HSCDT	HSC Development Team
HSCDM	HSC Development Manager
HSCOM	HSC Operations Manager
HSCOT	HSC Operations Team
HST	Herschel Science Team
H/W	Hardware
IA	Interactive Analysis
ICC	Instrument Control Centre
ICD	Interface Control Document
ICS	Instrument Command Sequence
IFOP	Instrument Flight Operations Plan
IFCP	Instrument Flight Control Procedure
ICRP	Instrument Contingency Recovery Procedure
IID	Instrument Interface Document
IOCR	In-Orbit Commissioning Review
ISO	(ESA) Infrared Space Observatory
ITT	Invitation to Tender
JD	Julian Day
KAL	Keep Alive Line
kb	kilobit
LAN	Local Area Network
LEOP	Launch & Early Orbit Phase
LOS	Loss Of Signal
L₂	L ₂ Lagrangian point of the Earth-Sun System



Mb	MegaBit
MCR	Mission Commissioning Review
MIB	Mission Information Base
MIRD	Mission Implementation Requirements Document
MIP	Mission Implementation Plan
MMI	Man Machine Interface
MOC	Mission Operations Centre
MS	Mission Scientist
MTL	Mission Time Line
OBSW	On Board SoftWare
ODB	Observation Data Base
PACS	Photodetector Array Camera and Spectrometer
PC	Personal Computer
PDB	Proposal Data Base
PES	Proposal Entry System
PH	Proposal Handling
PI	Principal Investigator
PLM	Payload Module
PM	Project Manager
PR	Public Relations
PRP	Public Relations Plan
PROM	Programmable Read Only Memory
PS	Project Scientist
PST	Project Scientist Team
PV	Performance Verification
PWG	Payload Working Group
QLA	Quick Look Analysis
QM	Qualification Model
RA	Right Ascension
RAM	Random Access Memory
RMS	Root Mean Squared
ROM	Read Only Memory
RTA	Real Time Assessment
SAG	Science Advisory Group
SCL	Spacecraft Control Language
SCOS	SpaceCraft Operations Control System
SCP	Satellite Commissioning Phase
SDB	Satellite Database
SEU	Single Event Upset
SIRD	Science Implementation Requirements Document
SIP	Science Implementation Plan
SOC	Science Operations Centre

SPACON	Spacecraft Controller
SMP	Science Management Plan
SPIRE	Spectral & Photometric Imaging REceiver
SPR	Software Problem Report
SPC	(ESA) Science Programme Committee
SRD	Software Requirements Document
SSAC	(ESA) Space Science Advisory Committee
SSD	(ESA) Space Science Department
SSMM	Solid State Mass Memory
SVM	Service Module
SVT	System Validation Test
SUM	Satellite Users Manual
S/C	Spacecraft
S/N	Signal to Noise
S/W	Software
TBC	To Be Confirmed
TBD	To Be Defined
TC	Telecommand
TM	Telemetry
TOO	Target Of Opportunity
TTC	Telemetry, Tracking & Commanding
URD	User Requirements Document
UT	Universal Time
UTC	Universal Time Cordinated
WIMP	Windows, Icons, Mouse and Pull-down menus
WWW	World Wide Web

1. INTRODUCTION

1.1 SCOPE OF DOCUMENT

This document, the (Herschel) Science Implementation Requirements Document (SIRD) contains the *formal requirements* for the scientific operations of the Herschel Space Observatory (formerly FIRST). These requirements are derived from the Herschel Operations Scenario Document (SD2) which provides a narrative elaboration of the ideas presented in the (then) FIRST Science Management Plan (SD1), but does not contain formal requirements. It also defines the related responsibilities and tasks of the various participants in the Herschel Project of ESA's Scientific Programmes.

These requirements are compatible with the overall Herschel mission concept and with the requirements levied on ESOC in the Mission Implementation Requirements Document (MIRD, AD12) – TBW by mid-2001 – for the implementation of the Herschel mission.

Implementation of the SIRD requirements shall be compatible with the programmatic, schedule and budgetary constraints applicable to the Herschel Programme.

During the design and development phases (phase B and phase C/D) the scope of the SIRD encompasses all tasks required for the provision of the necessary Herschel Science Operations facilities.

During the in-orbit operations phase (phase E), the scope of the SIRD encompasses all tasks required to carry out Herschel scientific operations in the optimal way compatible with the available resources. For this phase, the detailed activities required to support the scientific operations will be covered in the relevant operations-related documents which will be subordinate to the SIRD.

For the Post-Operations phase (see paragraph 2.4) the scope of the SIRD encompasses all tasks required to establish the Herschel “Archive” which is the ultimate legacy of the Herschel mission. As for the previous phase the corresponding detailed activities and supporting documents must be compatible with the SIRD.

The “Historical” Archive phase (see paragraph 2.4) is *not* covered in the SIRD.

The SIRD, therefore, has validity throughout all phases of the Herschel Programme, with the exception of the “Historical” Archive phase.

The SIRD will be placed under formal Configuration Control starting with Issue 1 (draft versions are not subjected to this mechanism). Changes in the contents of this document will normally result in changes in cost, schedule and/or performance. Any modification to the SIRD requires formal approval of the Herschel/Planck Project Manager, the Project Scientist (PS), the Principal Investigators (PIs), and the ESOC Ground Segment Manager (GSM).

Chapters 1 to 3, and chapter 7 provide background information.

The response to the SIRD will be contained in the Science Implementation Plans (SIPs)

generated by the entities responsible for implementation, namely the PIs (one SIP per instrument) and the PS for the HSC. The SIPs shall be limited to responding to the requirements set in chapters 4, 5, 6, 8 and 9 of the SIRD. They shall clearly identify the tasks and resources required to fulfill the SIRD requirements.

1.2 APPLICABLE / REFERENCE DOCUMENTS

Source documents

- SD1: [FIRST Science Management Plan \(ESA SPC\(97\)22, Rev. 1\)](#)
SD2: [Herschel Operations Scenario Document \(Herschel/HSC/DOC/0114\)](#)

Applicable documents

- AD1: FIRST/Planck System Requirements Spec. (SCI-PT-RS-05991)
AD2: - deleted-
AD3: [moved to SD1](#)
AD4: FIRST/Planck Instrument Interface Document, part A (SCI-PT-IIDA-04624)
AD5: FIRST Instrument Interface Document, part B
- Heterodyne Instrument (SCI-PT-IIDB/HIFI-02125)
- Photoconductor Array Camera and Spectrometer (SCI-PT-IIDB/PACS-02126)
- Spectral and Photometric Imaging Receiver (SCI-PT-IIDB/SPIRE-02124)
AD6: FIRST/Planck Operations Interface Requirements Document (SCI-PT-RS-07360)
AD7: ECSS - Space Engineering Software-, ECSS-E-40A
AD8: ECSS -Space Product Assurance – Software Product Assurance, ECSS-Q-80A
AD9: ESA Packet Telemetry Standard (PSS-04-106)
AD10: ESA Packet Telecommand Standard (PSS-04-107)
AD11: FIRST/Planck Packet Structure Interface Control Document (PS-ICD) (SCI-PT-ICD-07527)
AD12: Herschel/Planck Mission Implementation Requirements Document (MIRD) (TBW by mid-2001)
AD13: [moved to SD2](#)
AD14: Herschel Ground Segment Design Description (FIRST/FSC/DOC/0146)
AD15: [Herschel/Planck Ground Segment Documentation Plan \(SCI-PT-016463\)](#)

Reference documents

- RD1: FIRST Science Operations Concept and Ground Segment Document (PT - 03056)
RD2: The FIRST AO (PT-AO-3114)
RD3: Herschel Satellite Users Manual (TBW)
RD4: Herschel/Planck Mission Implementation Plan (MIP) -TBW-
RD5: HIFI Instrument Specification (SRON-G/HIFI/SP/1998-001)
RD6: PACS Instrument Description Document (no ref)
RD7: SPIRE Instrument Requirements Document (PT-07947)
RD8: moved to AD13
RD9: Herschel Common Science System URD (FIRST/FSC/DOC/0115)
RD10: Herschel Ground Segment Interface Requirements Document

(FIRST/FSC/DOC/0117)

RD11: moved to AD14

RD12: Herschel Ground Segment List of ICDs (FIRST/FSC/DOC/0150)

RD13: FIRST/Planck Consolidated Report on Mission Analysis (FP-MA-RP-0010-TOS/GMA)

RD14: - superceded by RD15 -

RD15: EGSE-ILT Users Requirements Document (FIRST-SPI-DOC-0127)

RD16: Quality Management System (QMS-ESOC-GSEG-WI-1001-TOS)

RD17: System AIV Requirements (SCI-PT-RS-07430)

RD18: ECSS-M-40A Configuration Management

RD19: HCSS Glossary (FIRST/FSC/DOC/0120)

1.3 Herschel MISSION OVERVIEW

1.3.0 Introduction

This section gives a brief mission overview for the benefit of clarifying the formal requirements that follow in subsequent chapters, cf. [SD2](#). Herschel is an observatory mission with a space segment including a PI provided science payload, and a ground segment provided by ESA together with the PIs, and an additional associated component provided by NASA.

1.3.1 Spacecraft

The spacecraft, of a modular design, (cf. figure 1.1) consists of three parts: the Telescope Assembly (TA) comprising the 3.5 m telescope inside its sunshade, the Payload Module (PLM), with the cryogenically cooled focal plane science instruments, and the Service Module (SVM) which also accommodates the “ambient” temperature payload electronics. The cryostat (which contains superfluid helium at 1.7 K) is directly derived from the ISO cryostat. The SVM is a new development.

1.3.2 Orbit

The nominal operational orbit for Herschel is a Lissajous orbit around the 2nd Lagrangian Libration Point (L_2) in the Earth/Moon-Sun system. Figure 1.2 shows the location of L_2 , the location of the other four Libration Points as well as the rotating orbit reference system $X_0Y_0Z_0$. The origin of this frame is at the Earth-Moon barycentre with the $+Z_0$ - axis pointing towards the North ecliptic pole and the $+X_0$ - axis pointing towards L_2 .

The in-ecliptic and out-of-ecliptic motions are periodic with a period of about 6 months. The orbit amplitudes are approximately within the following ranges:

X	200,000 - 360,000 km
Y	600,000 - 1,000,000 km
Z	150,000 - 650,000 km

The distance between the Earth and the spacecraft varies between 1.2×10^6 and 1.8×10^6 km and the Sun-S/C-Earth angle varies between about 8 and 40^o.

In the Lissajous orbit the spacecraft will be well outside the Earth's shadow and no eclipses will occur. The transfer trajectory can be designed such that it is also free of eclipses.

Details are to be found in RD13.

Fig. 1.1 The Herschel Spacecraft.



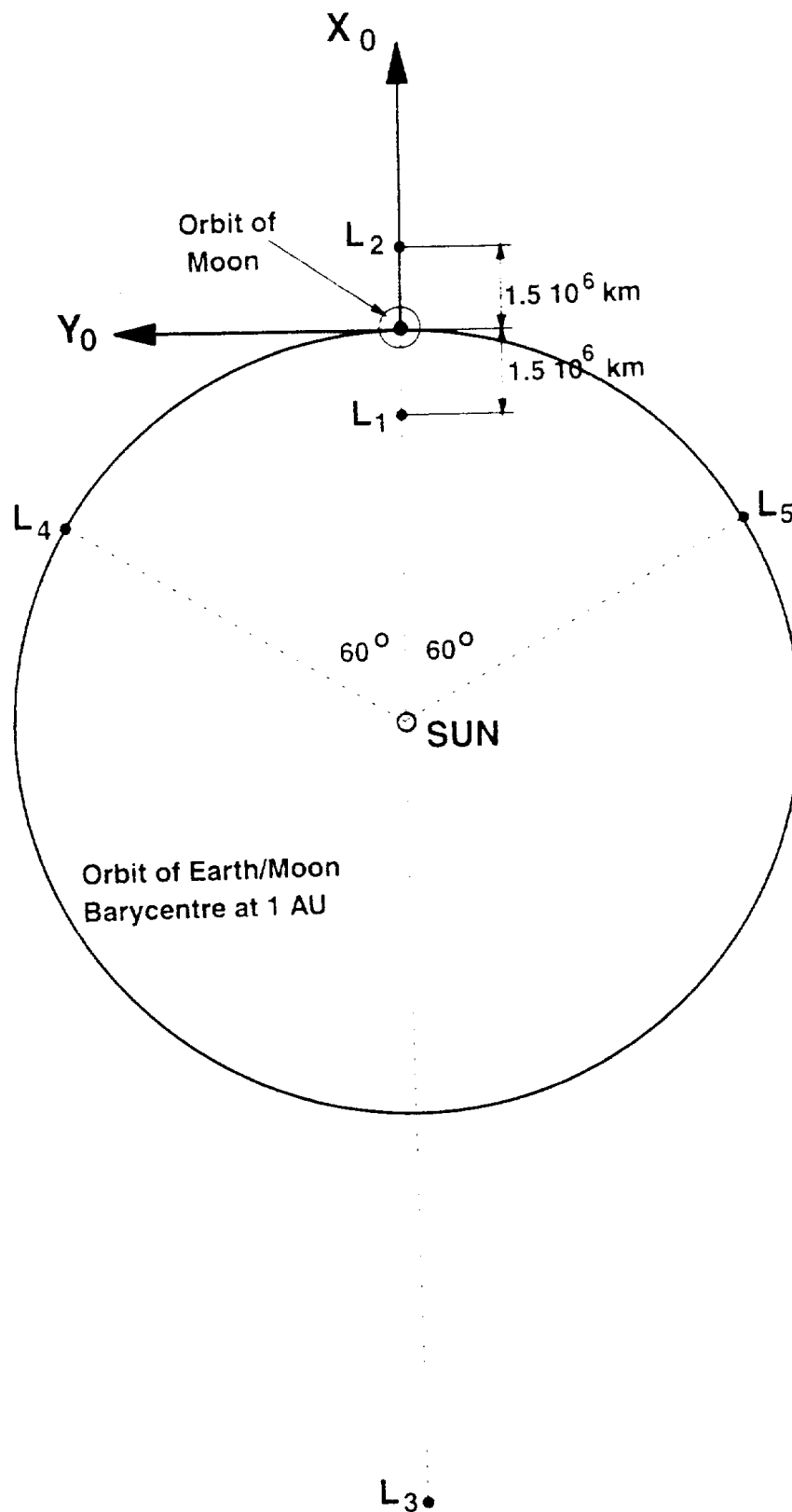

Fig. 1.2 The five Libration points and the rotating orbit reference system

1.3.3 Instruments

The scientific instruments are designed and built by consortia of institutes under the responsibility of a Principal Investigator (PI). The PI has the overall responsibility vis-a-vis ESA for the delivery of the instrument, and, in addition, for its corresponding Instrument Control Centre (ICC).

The Scientific Instruments are:

- The Heterodyne Instrument [for the Far Infrared](#) (HIFI)
Principal Investigator:: Dr. T. de Graauw (SRON – NL)
- The Photodetector Array Camera and Spectrometer (PACS)
Principal Investigator: Dr. A. Poglitsch (MPE – D)
- The Spectral and Photometric Imaging Receiver (SPIRE)
Principal Investigator: Dr. M. Griffin (QMWC – UK)

Details of the Scientific Instruments can be found in the Instrument Interface Documents (IIDs) – AD5 – as well as in RD5, RD6 and RD7.

1.3.4 Ground Segment

A top level functional representation of the Herschel Ground Segment for Herschel in the operational configuration consists of the elements shown in Fig. 1.3. Detailed descriptions are to be found in RD11.

The overall ground segment is implemented as a distributed architecture, where the required facilities are located in five distinct Centres as follows:

- the Herschel Science Centre (HSC), assumed to be located at Villafranca,
- the PACS Instrument Control Centre (PACS ICC), located at MPE, Garching,
- the SPIRE Instrument Control Centre (SPIRE ICC), located at RAL, Didcot,
- the HIFI Instrument Control Centre (HIFI ICC), located at SRON, Groningen,
- The Mission Operations Centre (MOC) [assumed to be](#) located in ESOC,

In addition, the NASA Herschel Science Center (NHSC) provided by NASA/JPL and located at the Infrared Processing and Analysis Centre (IPAC) at Caltech, Pasadena, is an associated centre, providing community support for US Herschel users. The SIRD does not put any requirements on the NHSC.

The major building blocks of the Herschel Ground Segment are shown in Fig. 1.4 (extracted from RD10).

The decentralised architecture of the Ground Segment implies that both development and operations are distributed across different sites. This is not a direct SIRD “requirement” as such since it is an implementation decision based on high-level considerations and constraints of the programme (e.g. funding constraints, requirement to limit staff out-posting, requirement that tasks must be carried out at the site where the expertise is

located, etc.)

The consequences of this decentralisation must however be fully addressed in the SIPs.

The dotted lines in Fig. 1.3 delimit the elements contributed by the various centres. Mission scheduling is seen as a shared responsibility between the HSC and the MOC. Interface with the Observers is an HSC responsibility. The Observers interact with the Ground Segment via the HCSS.

Data Communication lines link the ICCs to the HSC, and the HSC to the MOC. Non-operational communications between the centres are carried out via Internet (or equivalent), phone and mail.

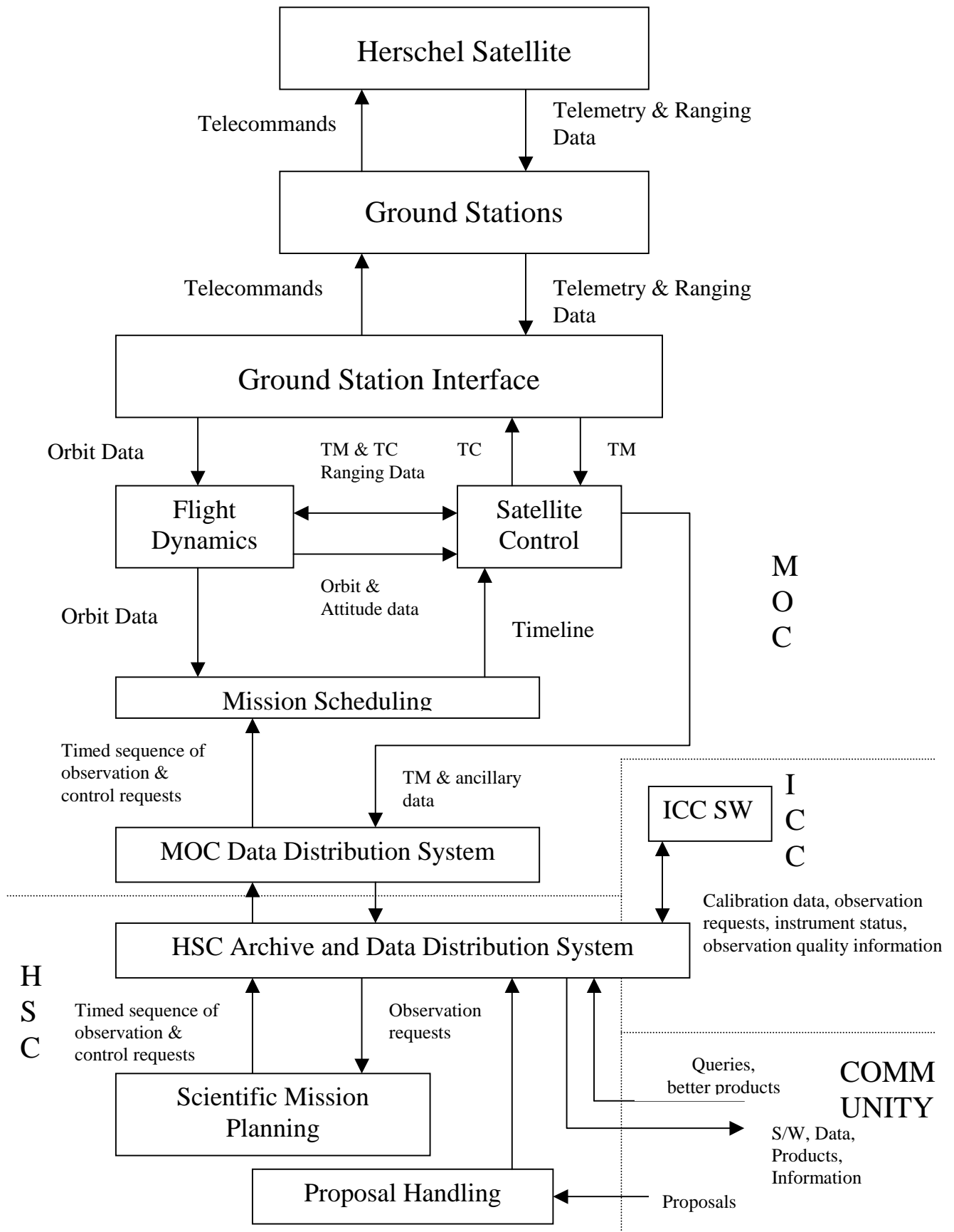

Fig. 1.3 Ground Segment Overview

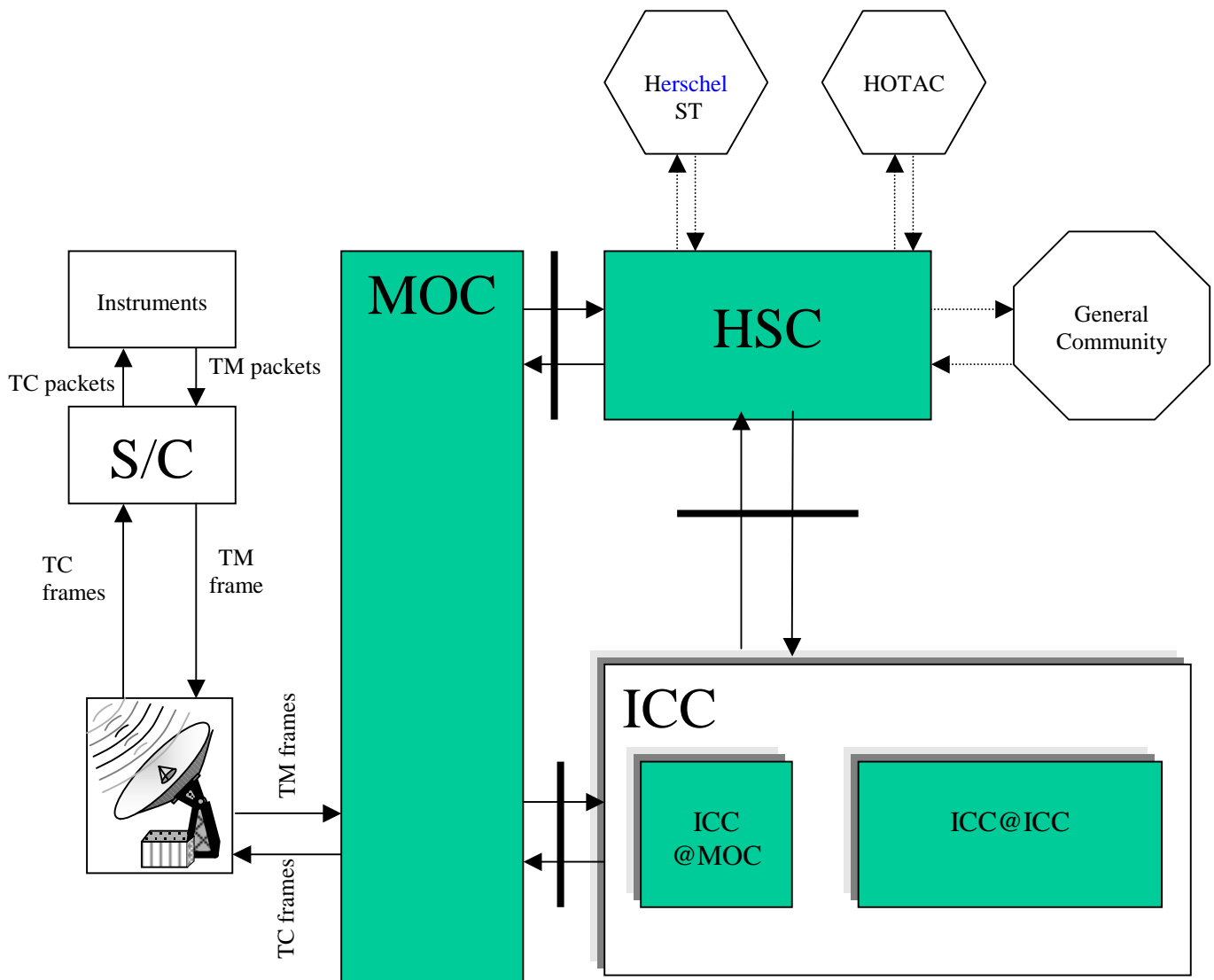

Fig 1.4 Herschel Ground Segment Interfaces during Operations

1.3.5 Operations

Herschel is an Observatory-class mission including key programs (e.g. surveys and other 'large' programs), guaranteed and open time.

From an L_2 orbit there are no constraints set by the Earth on the fraction of time which can be usefully employed as observing time. It is presently planned to conduct science operations 24 (TBC by the end of the industrial Phase B study) hours per day, out of which 3 (TBC) hours per day will be used for communication with the Ground Station by re-pointing the spacecraft antenna towards the ground station. (Note: Science data taken during this communication period will be constrained by the required antenna pointing). By analogy with ISO it is expected that dedicated instrument engineering/calibration tasks will require the equivalent time of about one day out of seven, or approximately 14% of the observing time. The remaining time will be divided into guaranteed and open time. The guaranteed time will be shared between the instrument/ICC PIs, the HSC, the Mission Scientists and the Optical Systems Scientist.

The open time will be allocated to the general astronomical community, including the guaranteed time holders, on the basis of submission of observing proposals and competitive selection. A small fraction of the open time will be allocated to discretionary time and Targets of Opportunity (ToOs). Given the science objectives of the Herschel mission it is anticipated that key projects in the form of large spatial and spectral surveys, as well as specific self-contained key programs, will consume a significant amount of the available time of the overall mission. It is foreseen that there will be a separate initial call for key program proposals at an early stage. When these programs have been established and after the Guaranteed Time proposals have been finalised the first call for normal observing proposals will be issued. At least one additional call for open time observing proposals will be issued after the initial survey data have become public.

Allocation of the available observing time, as well as selection mechanism and data access rights are described in [SD1](#).

During the Satellite Commissioning and Performance Verification phases two Ground Stations –[New Norcia](#) and Kourou- (TBC by end 2004) will provide extended coverage.

In routine phase all operations will be conducted through a single ground station ([New Norcia](#)).

The observation schedule will normally be executed autonomously from telecommands stored on board. The command schedule will be up-linked daily from the ground station(s).

Telemetry gathered during periods of non-visibility (routine phase) will be stored on board and transmitted in parallel with real time data when the satellite is in view of the ground station.

Spacecraft and instrument control will be performed by a single Mission Operations Centre (MOC) according to procedures. Specialists from the instrument developers will not be required during routine operations but will be accommodated at the MOC with their equipment during the Satellite Commissioning and Performance Verification phases and in case of contingencies.

All TM, TC and other operational data will be stored by the MOC in a data repository (Archive). From there this data is made available to the HSC as described in RD10 and RD11.

The observation pattern will nominally consist in scheduling a single instrument for extended periods of time e.g. 48 hours. Within this period the instrument will carry out observations lasting from minutes to hours. The other two instruments will be in stand-by mode (i.e. producing HK but no science data) except in the case when PACS and SPIRE are configured for parallel mode observation; whether or not this parallel mode exists is TBC by mid-2002.

The scheduling of observations will maximise scientific return. It will be stochastic but will permit some fixed-time observations. A mechanism will be provided to handle Targets of Opportunity (TOOs).

1.4 GLOBAL RESPONSIBILITIES

D/SCI has overall responsibility for all phases of the Herschel mission as part of the Herschel/Planck Project.

ESOC has overall responsibility for execution of all Herschel in-orbit operations.

ESOC has responsibility for the design, implementation and operation of the Herschel Mission Operations Centre (MOC), ground stations and related elements as well as for the Integration and Validation of the entire Ground Segment. This last task will be carried out under the authority of an ESOC Integration and Test Manager nominated by the GSM.

Responsibility for the design, implementation and operation of the ICCs rests with the PIs (each PI for the corresponding ICC).

Responsibility for the design, implementation and operation of the HSC rests with SCI-S.

During Phase B and Phase C/D overall project management is ensured by the Herschel/Planck Project Manager (H/P PM) located in ESTEC. During Phase E the overall management is ensured by the H/P PM up to and including the successful completion of the commissioning phase, at this point this responsibility is transferred to SCI-S. The Herschel Project Scientist represents the interests of the scientific community during all phases of the mission.

For all phases of Herschel development and operations a 'Herschel Ground Segment Advisory Group' (HGSAG), comprising representatives of the ICCs and ESA, monitors the activities of the main Ground Segment elements. It advises the Herschel/Planck Project Manager during the development and commissioning phases, and SCI-S during later operational phases.

1.5 MAJOR PROJECT MILESTONES

The following information is provided for the purpose of cost assessment only. The Project will review and update the project plan and milestones as necessary, but milestones changes will not lead to a separate update of this section.

1.5.1 Satellite Milestones

(1) System Review	Jul. 1997
(2) Issue AO	Sep. 1997
(3) Mission Approval & Payload selection	May. 1998
(4) Issue ITT (Phase B & CD)	Sep. 2000
(5) Start Phase B	April 2001
(6) Start Phase C/D	May 2003
(7) Instrument CQM deliveries	Dec 2003
(8) Instrument PFM deliveries	Jan 2005

(9) PFM System Test (start)	Feb. 2005
(10) Launch Campaign/Contingency (start)	Nov. 2006
(11) Launch	Feb. 2007

1.5.2 Ground Segment Milestones

The major Ground Segment Reviews are defined in RD16 which is applicable to ESOC following award of the ISO 9001 Certificate on the 30.11.1999.

RD16, strictly speaking, only covers ESOC's activities (e.g. MOC).

In order to ensure a controlled development of the entire Herschel Ground Segment, the Herschel/Planck Project will jointly, with ESOC, the ICCs and the HSC, organise intermediate reviews. It is expected that "lower" level reviews of specific Ground Segment elements e.g. HCSS will also be organised, with participation of the other contributors to the Ground Segment.

The following major GS-related milestones are defined:

(1) MIRD 1st Draft	Mar. 2001 (start Phase B—3 months)
(2) Customer Requirement Review	June 2001 (following MIRD release)
(3) MIP 1 st Draft	Sep. 2002
(4) MIRD final	May 2003 (end Phase B)
(5) Ground Segment Requirements Review	Jun. 2003 (L - 4 years)
(6) MIP Issue 1	June 2003
(7) Ground Segment Design Review	Feb. 2004 (L - 3 years)
(8) SVT-0	Aug. 2005 (L - 18 months)
(9) Ground Segment Implementation Review	Feb. 2006 (L - 1 year)
(10) SVT-1	April 2006 (L - 10 months)
(11) SVT-2	Aug. 2006 (L - 6 months)
(12) Ground Segment Readiness Review	Oct. 2006 (L - 4 months)
(13) Operations Readiness Review	15 Jan. 2007 (L - 1 month)
(14) Launch	15 Feb. 2007 (L)
(15) Mission Commissioning Review	May 2007 (L + 3 months)

1.6 TOP LEVEL DOCUMENTATION

Fig. 1.5 shows the top level documentation relevant to the Ground Segment activities. [This diagram is consistent with that presented in AD15.](#)

- The Science Management Plan (SMP) has been approved by the SPC in April 1997.
- The Herschel Operations scenario elaborated jointly by ESA and the PI-teams has been endorsed (with minor comments) by the (then) FIRST Science Team in April 2000, and subjected to formal review in November/December 2000. The Herschel Project Scientist is the 'custodian' of this document, which should be agreed by the Herschel/Planck PM, the ESOC Ground Segment Manager, and the three PIs.

- The Mission Implementation Requirements Document (MIRD) is generated jointly by the Project and ESOC. It must be “concurrent” to by the Project Scientist. It is formally issued by the Herschel/Planck PM. ESOC's formal answer is contained in the Mission Implementation Plan (MIP). The MIP must be approved by the PM.
- The Science Implementation Requirements Document (SIRD) -this document- is prepared by the H/P Project. It must be agreed by the PS, **concurrent** by the PIs, and the ESOC Ground Segment Manager. The SIRD is formally issued and approved by the Herschel/Planck PM.
- The HSC Science Implementation Plan (SIP), issued by the PS as a formal answer to the SIRD, specifies how (facilities, manpower, budget, schedule) SCI-S will implement the requirements put on the HSC by the SIRD. The HSC SIP shall be agreed by the H/P PM.
- Similarly each PI team will issue a SIP in response to the SIRD, specifying how its responsibilities as detailed in the SIRD will be fulfilled.
- The Herschel Common Science System (HCSS), developed jointly by the HSCDT and the PI teams, will be deployed in various configurations at the HSC and the ICCs. The implementation of the corresponding S/W elements will be controlled by the HCSS S/W Project Management Plan (SPMP). Because of this common development, the HSC SIP must be agreed by the PIs (or their representatives) and the PI SIPs must be agreed by the PS. The H/P PM does not have to agree to the ICC SIPs.
- The HGS-DD (RD11) provides a high level design description of the GS elements. The HGS-IRD (RD10) defines the functional, control flow and performance requirements applicable to the interfaces between these elements. The list of ICDs (RD12), derived from the HGS-IRD, identifies all individual interfaces (external and internal) between the GS elements and their corresponding sub-systems.

In addition to the documents mentioned above the following satellite-related documents are particularly relevant to the Herschel Ground Segment:

- The Instruments Interface Documents part B (IID-Bs), one per instrument, as well as the H/P IID-A, are initially issued by the H/P Project. The IID-Bs include the functional and instrument performance requirements which must be met by the instruments in order to fulfill Herschel scientific objectives. These requirements serve as a yardstick for evaluation of the instruments in-orbit performances. The IID-A describes the implementation of the instrument requirements in the design of the spacecraft. Starting with phase B the IIDs (A and Bs) will be maintained by the Prime Contractor in agreement with, and after approval by, the PIs and ESA.
- The System AIV Requirements Document (RD17) contains the top level requirements which ensure "smooth" transitions between the various mission phases.
- The H/P Operations Interface Requirements Document (H/P OIRD) is issued by ESOC. It specifies the requirements which must be fulfilled by the spacecraft and the

instruments in order to allow ESOC to operate them safely and efficiently (mainly requirements on TM, TC, autonomy, internal redundancy, etc.). The H/P OIRD must be approved by the PM.

- The Packet Structure ICD (PS-ICD) serves to complement and extend the TM and TC standards (AD9 and AD10) by defining all the mission specific details of the data transfer between ground and on-board applications (i.e. on-board units, subsystems, and instruments and their counterpart on ground).

Figure 1.5 Top Level of Herschel Ground Segment Documentation Tree

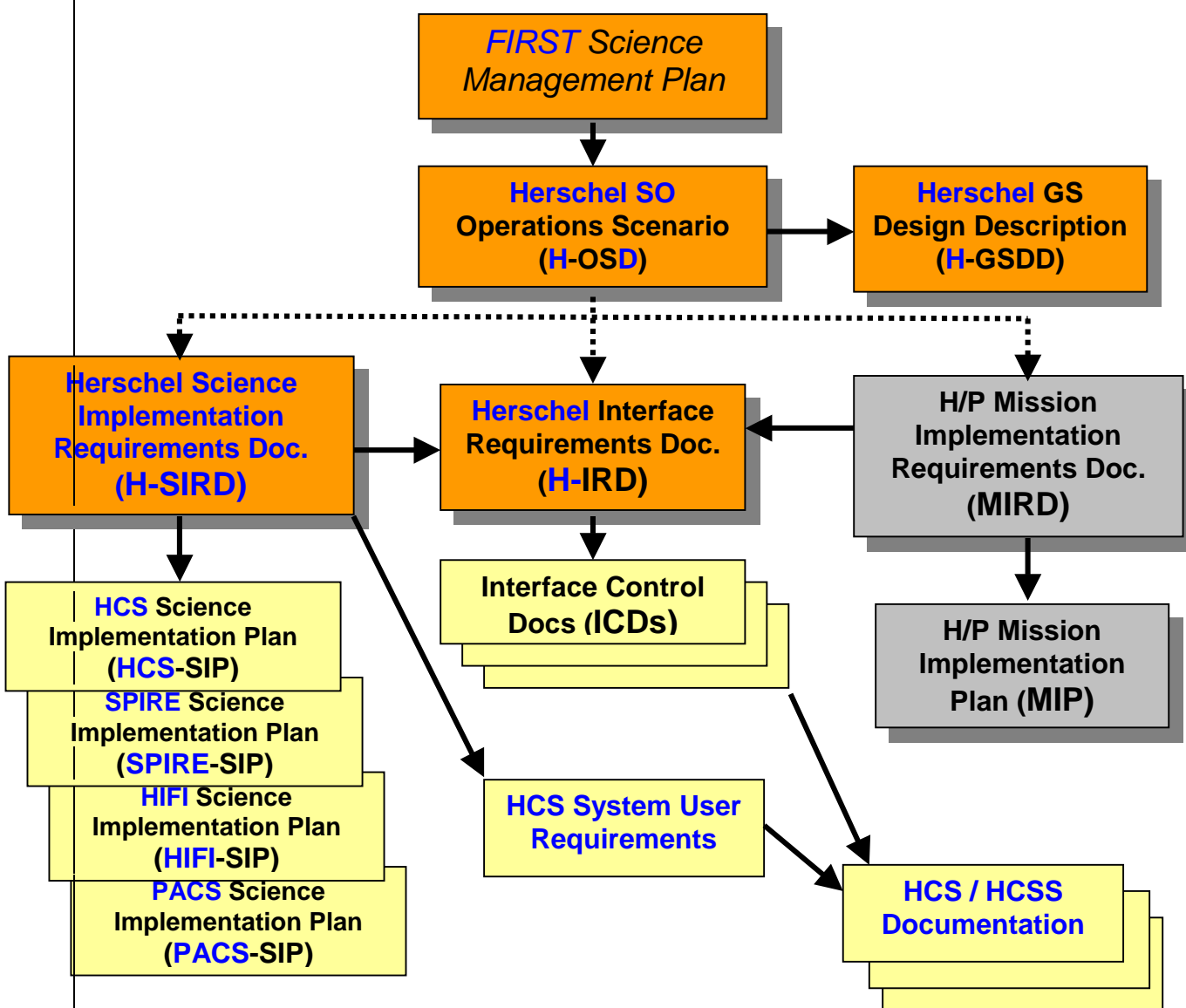

2. ASSUMPTIONS

The following assumptions are used as a basis for the planning of the scientific operations related tasks. It is understood that changes to these assumptions may change the scope and resources required.

2.1 LAUNCH

Herschel and Planck will be launched jointly from the Centre Spatial Guyanais (CSG) in Kourou, French Guiana, by a dedicated Ariane 5 into individual direct transfer trajectories towards their respective operational orbits around L₂.

2.2 ORBIT

The baseline is as described in RD13.

2.3 OPERATIONAL PERIOD

Launch date: 15 February 2007

Duration: 3.5 years of orbital operations: (3 years at L₂, up to 6 months transfer to L₂). Possible extension: max. 1 year (TBC post-launch).

2.4 MISSION PHASES AND FACILITY UTILISATION

The following mission phases are identified (in agreement with AD1). These phases are specifically applicable to the Ground Segment and operations. They are not directly relevant to the satellite programme (e.g. the launch campaign is not covered here).

The responsibilities for the various mission phases are described in section 7.

2.4.1 Development Phase

For the activities covered by the SIRD this phase formally starts at instrument/ICC selection and ends at the start of the LEOP phase. MOC, HSC and ICCs are involved.

2.4.2 Pre-launch Phase

From six to eight weeks prior to launch till launch minus 8 hours. This phase encompasses the final simulations and data flow tests, including Dress Rehearsal and the final Mission Readiness Tests (MRTs) between the ground stations, the MOC, the ICCs and the HSC.

2.4.3 Launch and Early Orbit phase (LEOP)

This phase comprises 3 sub-phases as described in AD1. They are briefly summarised here. During LEOP the instruments are switched off.

2.4.3.1 Launch Countdown Phase

Connection of the launch vehicle to the launch table, start of the final countdown sequence

(at $H_0 - 6h00$), RF flight configuration set up, switch over to internal spacecraft power.

2.4.3.2 Launch Phase

Starts with the removal of the umbilical and ends at separation of the spacecraft in a stable 3-axis attitude. Phase duration approximately 110 minutes (TBC through detailed analysis by mid-2006).

Note: Spacecraft separation (i.e. end of the Launch phase) marks the beginning of the Transfer phase to L2. The Transfer phase lasts up to 6 months (expected 4 months) depending on initial conditions and final orbit characteristics. Commissioning, PV phase, and part of the routine phase are thus carried out during the transfer phase.

2.4.3.3 Initial Orbit Phase (IOP)

After separation from the launch vehicle the ESA Network (Kourou, [New Norcia](#), Villafranca) establishes contact with the spacecraft for TC, TM and Ranging. The first orbit correction takes place as soon as possible after Launch and shortly after perigee (launcher dispersion removal manoeuvre). A second orbit correction (trim manoeuvre) is planned at Day 12 (TBC by mid-2006). If necessary a mid-course correction about 20 days before injection will be carried out to reach the correct conditions for entering the operational Lissajous orbit.

2.4.4 Commissioning Phase

Complete check-out of spacecraft functions and verification of all subsystem performances. About 3 weeks (TBC by mid-2006) after launch and after proper outgassing, the cryocover will be opened, the telescope decontamination heaters will be switched off, and payload functional checkout (by the ICCs) will commence.

Expected duration of the commissioning phase is 1 month (TBC by mid-2006).

Ground stations: [New Norcia](#) and Kourou (VILSPA as back up if required).

2.4.5 Performance Verification Phase

Starts after successful completion of the commissioning activities. In addition to the normal, routine satellite control, includes determination of the satellite pointing capabilities, calibration of the spacecraft sensors, determination of instrument performance in all modes, and initial instrument calibrations. MOC, ICCs and HSC are involved. Expected duration is about two months. The objective of this phase is to demonstrate the observatory (satellite + Ground Segment) scientific capability.

Note: Additional PV-like activities may be required outside the PV phase proper. In this case they would be scheduled as "normal" engineering/calibration/observation activities.

Note: ISO scientific operations have demonstrated that there is no sharp cut-off between PV activities and "nominal" routine phase activities. It is conceivable (likely) that for a given instrument some mode(s) will have been released for nominal, routine operations, while

other modes will still be under verification. The Ground Segment facilities (in particular mission planning and scheduling) shall ensure that this is possible without having to use specific, non standard, processes.

2.4.6 Routine Operations Phase

Nominal duration: Minimum 3 years at L₂.

2.4.7 Post-Operational Phase

The Post Operational Phase starts at the end of the orbital operations. It has a total duration of 5.25 years (TBC post-launch). It comprises the following sub-phases:

2.4.7.1 Run-down phase

Nominal duration: 3 months (TBC post-launch).

During this phase the final spacecraft calibrations accuracy data are derived (e.g. pointing), final spacecraft-related processing is carried out and the corresponding data are stored at the HSC. The necessary transfer of knowledge between MOC and HSC-ICCs takes place and the MOC dedicated facilities are dismantled.

The MOC is no longer involved in the subsequent activities.

2.4.7.2 Mission Consolidation phase

Nominal duration: 6 months (TBC post-launch).

Includes consolidation of the archive contents, including processing tools and documentation, as well as the tools necessary to allow the various users (e.g. 'browsers', 'surveyers', 'experts'. etc.) to access the archive.

2.4.7.3 'Active' Archive phase

Nominal duration: 4 years (TBC post-launch)

During this phase the HSC staff, the ICC staff and the scientific community access the Archive established at the end of the previous phase.

The experience gained and feed-back from the community are used to improve the instrument calibrations, cross-calibrations, processing tools as well as community support and access to the Archive (e.g. speed, flexibility and friendliness).

Complete reprocessing (TBC post-launch) of all observations is carried out, and the 'products' which will constitute the final archive are generated.

2.4.7.4 Archive Consolidation phase

Nominal duration: 6 months (TBC post-launch). The goal of this phase is, building up upon the previous phase, to provide a 'final', complete, stand-alone Herschel Archive of data, products, documentation and software that will - with zero further development and minimal maintenance and operational costs - permit continued exploitation of the Herschel legacy by the astronomical community for at least the following 10 years (TBC post-launch).

2.4.7.5 'Historical' Archive phase

Duration: at least 10 years (TBC post-launch). The 'Historical' Archive phase is *outside* the scope of the SIRD.

2.5 SATELLITE

Details on the Satellite, its performance and characteristics are contained in the applicable documents. Of particular note are the following:

- Herschel is a 3 axis stabilised satellite with 3 instruments.
- The satellite telemetry (TM) and telecommand (TC) will be in accordance with ESA packet standards. The satellite will provide the necessary resources for the average acquisition of at least 130 kbps science TM over 24 hours. In addition a high rate acquisition mode of up to 400 kbps for short periods (up to a few minutes) will be available.
- The satellite will be provided with a solid state mass memory (SSMM) which can store all necessary commands and data for a period of at least 48 hours (autonomy mode).
- The satellite will implement a survival mode that will ensure, for at least seven days without ground contact, the minimum operations required to maintain spacecraft and instruments in a safe configuration.
- Satellite pointing will be constrained by permissible earth and sun angles and be restricted by other bright celestial bodies.

2.6 ON-BOARD SOFTWARE

All instrument on board S/W will be maintained by the PIs pre- and post-launch. On board S/W management i.e. loading, dumping and comparing memory images will be carried out by the MOC.

3. RESPONSIBILITIES

Responsibility for the implementation of the Herschel ground segment and scientific operations is shared between:

- The Herschel Project Team (D/SCI-PT)
- The Directorate for Technical and Operational Support (D/TOS)
- The Project Scientist Team (D/SCI -SA)
- The Principal Investigators Teams (PI)
- The Herschel Science Centre Development Team (HSCDT)
- The Herschel Science Centre Operations Team (HSCOT)
- The Observers

D/TOS responsibilities are covered in the Herschel MIRD (AD11). The responsibilities of the other parties are defined in the following sections.

It has been decided in Summer 2000 that specific functional tasks which were initially allocated either to the HSC or to the ICCs will now be implemented jointly as components of the Herschel Common Science System (HCSS). Although an implementation issue, it is of sufficient importance to be mentioned in this document which strictly speaking is a requirements document. This implies:

- A re-allocation of (some of) the respective HSC-ICC responsibilities
- An increased HSC dependency on ICC deliveries (and vice versa!)

It should however lead to earlier and better coordination between HSC and ICC developments than was the case on ISO and to a reduction of the overall resources required through increased commonality.

As a result of the “smooth” transition concept the HCSS has to support the Instrument Level Tests (ILTs) and the Integrated System Tests (ISTs).

3.1 Herschel PROJECT TEAM RESPONSIBILITIES

The Herschel Project Team’s responsibilities are defined below.

Note: Most of the corresponding tasks are carried out in close collaboration with the other parties that have ground segment and operations responsibilities.

- establish the overall mission requirements.
- establish the concepts which ensure compatibility, commonality, and maximum re-use of hardware and software between all phases of the project.
- assume overall coordination for the definition and implementation of the elements of the Herschel Ground Segment and mission operations.
- define the interface requirements for the scientific instruments on-board software

design (F/P OIRD and PS-ICD).

- generate the MIRD and the SIRD. Update as required and keep under Configuration Control.
- approve all changes to the MIP and to the HSC SIP.
- monitor the design, development integration and validation of the Ground Segment.
- monitor flight operations procedures development (instruments and spacecraft).
- monitor ground segment operations procedures development.
- participate in the activities of the Herschel Ground Segment Advisory Group (HGSAG) chaired by the Project Scientist.
- participate in the activities of the Ground Segment Integration and Test Team (ITT).

Note: The ITT is set up and managed by ESOC. It must be established prior to the first SVT (MOC I/Fs and data flow: SVT-0).

- establish and maintain the overall Ground Segment schedule.
- monitor design and implementation of the scientific instruments including their on-board software.
- organise (jointly with ESOC and SCI-S) all major Ground Segment and mission operations reviews.
- assume overall responsibility for the definition and execution of the Satellite Commissioning phase (after which overall responsibility is assumed by SCI-S).
- provide ad-hoc specialist support during flight operations.

3.2 PROJECT SCIENTIST RESPONSIBILITIES

The Herschel Project Scientist (PS) is responsible for managing the Herschel scientific programme, safeguarding the scientific interests of the science community, and maximising the scientific return of the Herschel mission during all its phases.

The PS leads a team (the PST) which, advised by the Herschel Science Team (Herschel ST) and the Herschel Observing Time Allocation Committee (HOTAC) is responsible for formulating and implementing the overall science strategy.

The PS is ESA's interface to the scientific community, including instrument/ICC PI consortia, the Mission Scientists (MSs), the Optical Systems Scientist (OSS), and the HOTAC, for all Herschel scientific matters.

The PS liaises with the Herschel/Planck Project Manager (PM) and the Project Team in the development phase and coordinates all scientific issues with them. In particular the PS advises the H/P Payload System Manager on technical matters when they affect scientific performance.

After completion of the in-orbit operations the PS monitors the transition into the post-operational phase.

Within the framework of his overall responsibilities and within the context of Herschel science operations and Ground Segment the PS, supported by his team and the HSCDT, is, responsible for:

- issuing the Herschel Science Management Plan (SMP) and get it approved by the SPC.
- - organising the work of and chairing the meetings of the Herschel Science Team (Herschel ST)
- issuing the "Scientific Capabilities of the Herschel Payload" document.

Note: This document summarises the characteristics and expected performances of the three Instruments that form the scientific payload of Herschel.

- supporting all Ground Segment reviews.
- chairing all meetings of the HGSAG.

3.3 PI RESPONSIBILITIES

Each Herschel Principle Investigator (PI) shall set up a dedicated Instrument Control Centre (ICC). He shall nominate an ICC manager, reporting to him, or the instrument's Project Manager, who shall have full authority for the day-to-day management of the ICC.

The primary role of the ICC is to make possible the processing of the instrument data into scientifically useful products. It does this by providing the necessary software and expertise to allow the definition of astronomical observations and engineering tests and the processing of data taken from their measurement into usable products.

The ICC is also responsible for the monitoring and maintenance of the instrument scientific performance throughout the mission.

Note: All PI ground segment-related contributions to the overall GS will be provided either by the ICC team or the Instrument team. The SIRD makes no specific assumptions as to the relative contributions of each team. This is left entirely to the PI. Some requirements in chapter 4, although specified as requirements on the ICC, can therefore be fulfilled by the Instrument Team, the ICC team or jointly by both.

3.4 Herschel SCIENCE CENTRE (HSC) RESPONSIBILITIES

The Herschel Science Centre (HSC) is the prime interface to the outside world -including not only the general scientific community but also the press and general public. It is assumed to be located at Villafranca (E). Provision of the HSC is a SCI-S responsibility.

The HSC has two fundamental functions:

- It shall ensure that the scientific productivity and impact of the Herschel mission is maximised within the given constraints. This is the responsibility of the Project Scientist Team (PST) led by the Project Scientist.
- It is responsible for the provision of a number of sub-systems (or functions) belonging to the Herschel Common Science System (HCSS) which is developed jointly with the ICCs. The corresponding tasks are the responsibility of the HSC Development Team (HSCDT) which is led by the HSC Development Manager (HSCDM). The HSC Operations will be the responsibility of the HSC Operations Team (HSCOT) led by the HSC Operations Manager (HSCOM). It is expected that the HSCOT will be built up progressively to reach full strength a few months before launch. It is further not excluded that (at least some) members of the HSCDT will become members of the HSCOT as the emphasis switches from development to operations. Both HSCDM and HSCOM are ESA staff members reporting through the SCI-S structure.

3.5 OBSERVERS RESPONSIBILITIES

Observers and potential observers have no responsibility as such in the science operations. They, however, play an active role in the overall activity of the Herschel Observatory. They communicate with the HSC, at their own cost, through normal means such as the World Wide Web (WWW), electronic mail (E-mail), and other Internet-like services, fax and phone. In some cases visits to the HSC may be required. Their responsibilities are listed below:

- send a letter of intent to the HSC (TBC by end-2002 through further definition of the proposal submission process) prior to formally submitting observing proposals.

Note: this is one possible mechanism that allows formal user registration at the HSC.

- access the Call for Proposal documentation and associated supporting software (through WWW or equivalent). Generate, check and submit observing proposals to the HSC.
- communicate, as required, with the HSC central help-desk facility.
- update their observing proposals post-launch, as required, according to the HSC instructions, in order to take into account the in-orbit performance of the satellite.
- access (through WWW or equivalent) the facilities (log of observing proposals, status of executed observations, etc.) required to assess the status of their proposals/observations.

-
- access their observation data as well as the auxiliary data, calibration data and scientific processing software required to process their observations. Generate the corresponding output products.
 - access (through the WWW or equivalent) as required, every data of interest which is publicly available (e.g. newsletter, publications, official Herschel documentation, etc.).
 - (for specific users) draft/supply, upon HSC request, material for press releases, PR activities, etc.
 - provide feedback to the HSC on Herschel scientific operations.
 - provide feedback of data processing and software.
 - feed published processed data back into the archive.

4. INSTRUMENT CONTROL CENTRE: DELEGATED TASKS

4.1 FUNCTIONAL REQUIREMENTS

Under the PI authority, the ICC manager and his team are responsible for the following tasks: (*but see 3.3*)

- ICCF-005 establishment, jointly with ESA, of the detailed list of ICC tasks and deliveries (*see also chapter 9*).
- ICCF-010 generation of the ICC Science Implementation Plan (SIP).
- ICCF-015 overall ICC organisation. ICC Team set up and management.
- ICCF-020 establishment and maintenance of the ICC schedule.
- ICCF-025 management of the ICC interfaces with the ESA Project Team, the other ICCs, the HSC and the MOC.
- ICCF-030 support to the ground segment reviews.
- ICCF-035 ICC Manager attendance (as a permanent member) to the meetings of the HGSAG.
- ICCF-040 establishment, jointly with SCI-S, of the set of documents (including software documentation) to be produced by the ICC.

Note: It is expected that, in addition to the ICC-SIP, the ICC will produce requirements documentation (URDs or use-case documents) , an ICC WBS with the corresponding WPs and a Software Project Management Plan (SPMP). As far as ICC contributions to development of the HCSS are concerned, this might be in the form of contributions to corresponding HCSS documentation.

- ICCF-045 provision of infrastructure (building, hardware, office space, communication equipment, etc.) as well as the support facilities (secretariat, clerical support, etc.) required, pre- and post-launch, to support the development, and later, mission operations work allocated to the ICC .

Note: ICCF-050 to ICCF-110 are carried out in close collaboration with the instrument designers.

- ICCF-050 definition of the various TM and TC packets required to operate the instrument.
- ICCF-055 definition of the various instrument modes.

-
- ICCF-060 definition of the set of command sequences necessary to operate the instrument.
- Note: This set will be available to the Mission Planning and Scheduling systems.*
- ICCF-065 definition and delivery to the MOC –via the HSC– of command sequences which need to be permanently available at the MOC to support manual commanding of the instrument during the DTCP.
- Note: This set will be available to the SPACONs . It contains a set of fixed command sequences, normally not used for observations, e.g. test and diagnostic, tuning, contingency switch-off, etc.*
- ICCF-070 definition of the initial set of Astronomical Observation Templates (AOTs) required to carry out the instrument scientific and standard calibration observations.
- Note: The AOTs implement, at user level, the instrument modes defined in ICCF-055.*
- ICCF-075 definition of the parameters required to ensure instrument health and safety “monitoring” by the MOC. This includes:
- definition of the set of instrument-HK parameters to be monitored
 - definition of the relevant “event messages”
 - definition of the corresponding “TC verification messages”
- Note: MOC will only monitor instrument parameters contained in HK TM (which includes event packets).*
- In particular for each of the parameter to be monitored:
- definition of the parameter limits (if applicable: hard and soft)
 - definition of the validity conditions
 - definition of the conditions under which a reaction is required
 - definition of the action to be taken (when conditions are met)
 - specification how many times the parameter has to be out-of-limits before an action is taken
- ICCF-080 definition of instrument TM in such a way that all information required to process the data on ground can be identified from the contents of the TM (e.g. definition of instrument dummy commands and associated parameters; *directives, observation_IDs, building_blocks_IDs*, etc.).
- ICCF-085 provision of the instrument TM/TC data base, in an agreed format, to the Herschel/Planck Prime Contractor for inclusion into the Satellite Data Base.
- Note: In view of the decision made by all ICCs to base their RTA on SCOS*

2000, the "agreed format" complies with the SCOS 2000/MIB I/F.

ICCF-090 provision of the Instrument Users Manual including all Instrument Operational Procedures.

ICCF-095 generation and validation of the nominal and contingency Instrument Operations Procedures. This would typically include:

- start up procedure
- instrument commissioning procedures
- "first light" procedure
- engineering and diagnostic procedures
- shut-down procedure
- calibration procedures
- observation procedures
- instrument on-board S/W update procedure
- reset procedures (i.e. procedures to set the instrument into any predefined standard default mode)

Note: The instrument operations procedures will be incorporated into the Flight Operations Plan by the MOC together with any related spacecraft procedure. These procedures support "manual" commanding during the DTCP.

ICCF-100 generation and validation of the On-Board Control Procedures (OBCPs) and/or functions, in particular the "autonomy" procedures. This would typically include:

- procedure for time synchronisation
- procedure for communication with the CDMS (TBC during Phase B)
- procedure for communication with the AOCS (TBC during Phase B)
- "saving" procedures (i.e. procedures to cater for unforeseen events such as bright star crossing the field of view)
- back-up procedures (e.g. activation of a redundant sub-system in case of failure of the prime system)
- procedures for safety parameters out of limits
- procedures for recovery from instrument command verification failure
- procedures for other instrument anomaly recovery
- procedure for instrument emergency switch-off

Note: The OBCPs must take into account the requirements for instrument autonomy, i.e. the instruments shall be able to operate for extended periods without ground control. It is expected that the "autonomy" procedures will constitute a (large) sub-set of the OBCPs. The OBCPs run "on top" of the instrument OBSW.

Note: "functions" (as defined in AD11) provide a functionality similar to the OBCPs (also defined in AD11). It is up to the PI-teams to select the most appropriate implementation of the autonomy requirements.

- ICCF-102 provision (jointly with the HSC) of the Instrument Observers Manual.
- Note: This manual specifies how the “observer” can carry out “observations” with the corresponding instrument. The Observers Manual is complementary to the Instrument Users Manual which covers engineering aspects of the instrument.*
- ICCF-105 provision of a "time estimator" for the instrument.
- Note: The "time estimator" for each instrument will be part of the Common Uplink System (CUS). Depending on the development status of CUS, including AOT definitions, a separate, much simpler time estimator might be necessary for proposal submission phase one.*
- ICCF-110 - deleted - This requirement has been merged with ICCF-085 due to the use of SCOS 2000 for RTA and a MIB editor to supply instrument data in a format recognised by ESOC to the generation of an operational satellite DB at the MOC.
- ICCF-115 generation and validation of the ground segment-related ICC Operational Procedures (nominal and contingency).
- ICCF-120 definition (jointly with ESA) of the instrument data to be stored in the Science Archive.
- ICCF-125 definition (jointly with ESA) of the relationships between these data items, and the HSC and MOC-provided data items.
- ICCF-130 design, implementation, test and validation of the S/W required for the scientific processing of instrument data. This includes:
- Real Time Assessment (RTA) S/W
 - Quick Look Analysis (QLA) S/W
 - Interactive Analysis (IA) S/W
 - Any ad-hoc tool (e.g. uplink-downlink correlators, telemetry viewers, non-standard data processing packages, etc.)
- Note: Interactive Analysis shall allow observers to*
- *generate calibrated data from raw telemetry,*
 - *further analyse this data (possibly outside the provided IA, if sufficiently free of instrumental signatures to allow this) to produce reduced scientific data ready for publication.*
- Interactive Analysis shall allow HSC to generate QCP products from a scripted chain of IA modules.*
- Together with ad-hoc tools or tools that may be part of IA but are not available outside the ICCs, IA shall allow ICCs to perform trend analysis to characterise the long term behaviour of instrument and detectors and to perform calibration analysis.*

- ICCF-135 definition (jointly with the PST) of the Instrument Calibration Plan.
- Note: This Plan should cover pre- and post-launch instrument calibration activities.*
- ICCF-140 generation and management of the instrument ground calibration data.
- ICCF-145 Define (jointly with the HSC) a calibration programme based on ground and space facilities which might be necessary to support instrument calibration pre- and post-launch.
- ICCF-146 Define (jointly with the HSC) the instrument calibration requirements.
- ICCF-147 Define (jointly with the HSC) the Instrument in-orbit Performance Verification Plan.
- ICCF-148 Prepare (jointly with the HSC) the in-orbit instrument calibration programme.
- ICCF-150 provide to MOC all the necessary definitions, all the requested information and instrument user's manuals for the development of the Instrument S/W Simulator. The following high level requirements must be taken into account:
- the simulator shall be adequate for validation of instrument flight operations procedures and scientific processing S/W.*
- *the simulator is required to behave w.r.t. command and HK TM in a way which is an accurate simulation of the instrument (in real time)*
 - *the data exchanged with the CDMS shall faithfully represent the instrument in terms of status (in HK TM, command verification and events).*
 - *Parameters on the basis of which operational decisions are to be made shall be modelled with an appropriate "fidelity".*
 - *Science data only need to be representative –TBC– (i.e. volume and mix of packets should be correct, but the packet contents need not be meaningful).*
- Note: The level of fidelity" required from the Simulator must be agreed between the ICC, the MOC and the Project Scientist.*
- ICCF-151 support the development, test and validation of the S/W Instrument Simulator developed by MOC.
- ICCF-152 - deleted as a separate requirement - subsumed under ICCF-150.
- ICCF-153 analyse the use of/need for, and then correspondingly specify and provide all the pertinent information required by MOC for the design,

implementation, test and validation of the means to let instrument software simulators generate science data packets with "realistic" contents for a variety of purposes. The functions that might need to be supported by the provision of such data include:

- Validation of correct HCSS implementation,
- Validation of instrument mode or on-board SW changes wrt their impact on science data contents,
- ICC and HSC operator training,
- Preparation of end-to-end tests,
- Validation of procedures that involve ICCs or HSC and the interactions between ICCs/HSC/MOC.

ICCF-155 set up and maintain at the ICC an instrument on-board S/W maintenance and validation facility. (Pre- and post-launch)

ICCF-160 deliver to the MOC (via the HSC) the instrument on-board software uplink images according to an agreed format.

- format to be defined in an ICD produced by the MOC.
- format will be the same for all instruments.

Note: The following assumptions can be made with some confidence, based on previous projects (TBC in the ICD which will be established between MOC and HSC):

- complete images are delivered to the MOC
- The MOC is expected to carry out an incremental (small) patch process
- The procedures for the patch implementation are delivered with the image.

ICCF-165 define jointly with the HSC the data and operational interface between the ICC and the HSC.

- the interface will be defined in an ICD produced by the HSC.
- the interface will be identical for all ICCs.

ICCF-170 define jointly with the MOC the data and operational interface between the ICC and the MOC.

- the interface will be defined in an ICD produced by the MOC.
- the interface will be identical for all ICCs.

Note: ICCF-170 refers to the so-called ICC@MOC i.e. to the ICC system deployed at the MOC to support the Commissioning and Performance Verification phases. This system which will be left at the MOC can be "re-activated" in case of serious instrument problems during the routine phase. In routine phase there is no direct MOC-to-ICC (i.e. the so-called

ICC@ICC) interface. The interface is non-real time and is via the HSC.

Note: There are no formal data or operational interfaces between the ICCs. It is expected, however, that communications between the ICCs will be frequent and extensive in order to achieve the commonality objectives of the Herschel programme.

- ICCF-175 provide support for the definition and design of the HCSS.
- ICCF-176 design and implement the instrument-specific HCSS components as well as agreed general components that form part of the common development.
- ICCF-177 provide support to the HSC for the integration, test and validation of the full HCSS.
- ICCF-180 ensure that the commonality standards defined jointly with the HSC and the other ICCs are adhered to in the HCSS S/W design and implementation.
- ICCF-185 set up and operate (pre- and post-launch) the ICC hardware and software Configuration Control System (CCS).
- Note: It is desirable that the S/W CCS adopted for the HCSS is such that it can also be used for the ICC-specific components which do not belong to the HCSS under the authority of local configuration controllers.*
- ICCF-190 provision, to the agreed standards, of all ICC-related documentation. This includes:
- on-board S/W documentation
 - instrument simulator documentation
 - S/W users manuals
 - ICC H/W and S/W Integration and Test Plans
 - S/W test procedures and test results.
 - ICC Operations Plan
- ICCF-195 provide the necessary input, as required, to the Integration and Test Team (ITT) for the generation of ground segment Integration and Validation Plans, as well as Simulation Plans.
- ICCF-200 participation, as required, in pre-launch ground segment integration tests, validation tests (e.g. listen-in, SVTs, end-to-end tests, etc.) and simulations.
- ICCF-205 deliver to the MOC the necessary hardware (Instrument Station) and software (RTA and QLA, etc.) required to support the Commissioning and Performance Verification phases (the so-called ICC@MOC). Support installation as required.

ICCF-210 (was ICCA-010): define (jointly with the HSC) the type of data and data “products” to store into the archive for the various types of users (e.g. “browsers”, “survey” users, “experts”, etc.)

Note: The ISO Data Archive distinguishes between the following types of users:

- *"Browsers": Their interest is to quickly scan/preview archived products to determine the possible use of a particular product in their work. Their use of the archive is of a very exploratory nature and relies on the existence of "quick look/thumbnail" products.*
- *"Survey researchers": Their interest is to extract uniformly processed data for a large group of sources of a given class without having to get involved in details of the data reduction.*
- *"Single/few source researchers": Their interest is to retrieve data for a very limited number of sources for special processing with the best possible calibration.*
- *"Expert users": Rather than being interested in any archived, "pre-fabricated" products, instrument specialists/highly informed users wish to process the data themselves, often with a specific purpose in mind, e.g. to derive a model for the behavior of a particular instrument parameter that would improve the quality of reduced data for a given instrument mode.*

ICCF-215 (was ICCA-015): define (jointly with the HSC) the processing tools and archive access tools to be provided, as well as data quality goals.

4.2 OPERATIONAL REQUIREMENTS

ICCO-005 set up and train the ICC operations team required to support the instrument operations during all phases of the mission.

Note: The operations staff will be located at the ICC during the routine phase. The necessary accommodations and logistical support shall be provided by the ICC

ICCO-010 provide instrument training, as required, to selected HSC and MOC staff.

Note: Training shall take place on ICC premises in accordance with a training plan approved by ESA. The plan shall identify duration of each training activity and number of staff involved -trainers and trainees-.

ICCO-015 provide to the MOC the operations staff (instrument specialists) required to support the Commissioning and Performance Verification phases.

Note: These specialists will be located at the MOC for the duration of these two phases. The necessary accommodations and logistical support

will be provided by the MOC

At any time in the course of the mission ICC staff may have to be recalled at the MOC to provide payload contingency support in case of serious malfunction of the instrument.

The scope and/or frequency of some of the operational tasks listed below might change between the various mission phases. The details shall be elaborated in the relevant operations plans. In broad term the ICC operations will entail the following tasks:

ICCO-020 maintenance of the instrument on-board S/W until the end of orbital operations.

Note: This includes diagnostic of the malfunction or improvement required, implementation of the required S/W changes, validation on the ICC-provided on-board S/W validation facility and submission of the changes to the MOC via the HSC.

Note: A new on-board S/W version can only be uplinked upon Project Scientist approval. Uplink is carried out by the MOC according to agreed operational procedures.

ICCO-025 support the HSC helpdesk on specific instrument-related queries

Note: This is for queries from the community that the HSC cannot answer directly. This includes queries on instrument-related software. It is anticipated that this is only a punctual, low-level activity. Interaction is with the HSC not directly with the originator of the query.

ICCO-027 support the MOC by providing updated instrument databases.

Note: This extends requirement ICCF-085 into the context of operations.

ICCO-030 provision of instrument "calibration" requests, instrument "engineering" requests, instrument "diagnostic" requests, instrument "on-board memory dump requests", etc. to the HSC for the upcoming mission planning period.

Note: requests to be provided nominally 2 to 3 weeks in advance, for a period of 2 to 3 weeks according to agreed procedures (TBC in an "operational interaction document" to be established prior to launch). If re-planning is required the turn-around time will be faster.

ICCO-035 during Instrument Commissioning and contingencies, perform (near real-time) instrument health and status monitoring (RTA). This includes;

- get (near real-time) TM data from the MOC
- display and monitor instrument status.
- derive and display additional parameters. perform limit checking.
- perform instrument command verification (TBD)

- identify possible instrument reconfiguration and/or changes in parameter settings for current or future observations (TBD)
- provide instrument mode/parameter change requests to the MOC (TBD)

Note: This function is carried out on the Instrument Station (IS) running RTA. During Commissioning and PV phase one IS is located at the MOC (ICC@MOC) and one (or several) IS(s) is (are) located at the ICC (ICC@ICC). Instrument “safety” is ensured by the MOC. In the context of the SIRD the IS is a generic name identifying the H/W upon which the suite of S/W required to support the ICC (ICC@MOC and ICC@ICC) will run. It does not necessary imply a single H/W platform.

ICCO-040 during Instrument Commissioning and contingencies, perform (near real-time) instrument performance monitoring. This could include:

- select and display science data.
- derive and display additional parameters.
- perform preliminary assessment of detector behaviour (sensitivity, saturation, spiking, dark current, etc.)
- perform pointing verification (TBD)
- establish if spacecraft attitude trim is required (TBD)
- identify possible instrument reconfiguration and/or changes in parameter settings (e.g. gain settings, bias voltages, change of filters, etc.) for current or future observations (TBD)
- produce IS report and file -preliminary assessment of success/failure of the observation-.
- provide instrument mode/parameter change requests or spacecraft attitude trim requests to the MOC (TBD).

ICCO-042 perform instrument aperture misalignment measurements against the satellite reference axes.

ICCO-045 perform RTA and QLA functions in off-line mode.

Note: This function is carried out at the ICC@ICC using data retrieved from the HSC.

Note: In the routine phase, the data gathered on-board during the Daily Science Operations Phase (DSOP) is already “old” data by the time it is transmitted to the ground during the DTCP (Daily TeleCommunication Period) and made available at the MOC. Near real-time data during the routine phase is thus only the data gathered during the DTCP and transmitted in parallel to the stored data.

ICCO-050 perform instrument calibration. This includes:

- schedule “calibration” observations on external standard calibration sources.

- schedule “calibration” observations with instrument internal calibration sources.
- process calibration observations.
- compare calibration derived parameters with pre-launch values.
- update calibration files/tables (e.g. Cal_G and Cal_Q files for ISO) and archive.
- update calibration history
- carry out Trend Analysis
 - Derive long-term trend data for instrument performance evolution.
 - Derive instrument calibration tables (e.g. CAL_U files in ISO) and archive.

ICCO-055 propose changes to instrument operations scenario. Coordinate with MOC and HSC.

Note: It may be that, based on the results of any of the activities ICCO-035 to ICCO-050, the instrument operations scenario for the instrument has to be changed. Instrument operations may have to be suspended until further notice in case of serious instrument malfunction and/or it may be that a specific instrument mode (or AOT) does not work. It is the responsibility of the ICC operations staff to propose changes to the operations scenario in order to overcome the problem(s).

Note: changes must be coordinated with the MOC and HSC and can only be implemented after Project Scientist authorisation. Implementation is carried out by the HSC Operations Manager.

ICCO-060 support “specific” instrument modes (TBD). This could include:

- instrument “parallel” mode (SPIRE parallel to PACS).
- Instrument “serendipity” mode (i.e. instrument observing during “slews”)

Note: Specific instrument modes, if defined, shall be supported (planning, health and performance monitoring, calibration, data analysis, etc.) by the ICC operations teams in agreement with the overall science objectives established by the Project Scientist.

ICCO-065 validation of the scientific processing S/W prior to delivery to the HSC for release for use by the community.

Note: the scientific data processing software will evolve considerably during the mission from the basic, imperfect set available at launch. The ICC teams shall process “selected” observations in order to validate the various processing algorithms. Upon validation the S/W is released for use by the HSC and the community. The Observations to be checked shall be selected in such a way that all instrument modes (AOTs) are covered as well as possible.

- ICCO-070 perform quality checks of the mission products. This includes:
- verification of the processing algorithms used in product generation
 - verification of the instrument calibration
 - checks on the contents and structures of the data products
 - checks on actual instrument sensitivities
 - checks on actual noise levels (e.g. due to radiation, detector aging)
 - checks on saturation
 - checks on the presence of spurious features
- Note: “standard” products (these are TBD) are derived by the HSC and/or the users (“on-the-fly” processing) applying the scientific data processing S/W to their observation data. The ICC team shall process “selected” observations at regular intervals in order to verify that the products derived from this processing satisfy the required quality standards. This activity is closely related with ICCO-065.*
- Note: It is the current baseline that the HSC will systematically “quality check” **all** products before their release.*
- ICCO-072 [Support cross-calibration of their instrument with other instruments.](#)
- ICCO-075 maintain optimal scientific instrument performance. This includes:
- regular generation of instrument calibration parameters.
 - maintenance of AOTs and Command Sequences.
 - maintenance/update of the on-board S/W.
 - issue, as required, Instrument Anomaly Reports.
 - adaptation to radiation environment.
- ICCO-080 maintain the ICC. This includes the following tasks:
- maintain and update as required the general ICC infrastructure.
 - maintain and update as required the ICC software.
 - maintain and update as required the ICC hardware. Carry out regular preventive H/W maintenance (including installation, if necessary, of new versions of operating systems)
 - perform routine S/W and data backups.
 - maintain the ICC documentation.
 - train (re-train) ICC staff as required.
 - operate the ICC hardware and software Configuration Control system. (maintain a central list of all ICC Software Problems Reports)
- ICCO-085 produce monthly ICC operations reports.
- ICCO-090 provide information (e.g. documentation, recipes) and support to the HSC to help the archive users in the reduction of their data.

4.3 POST-OPERATIONS REQUIREMENTS

These activities concern essentially the tasks required to produce an archive of Herschel data and data products, processed with the best calibration possible and make them available to the community. The tasks are shared by the HSC and the ICCs. The HSC contribution is described in chapter 5.3.

The ICCs shall, as a minimum, carry out the tasks listed below. The list is limited to the tasks required in support of the Herschel mission. The ICCs may want to perform additional ICC-specific tasks. In this case the ICC manpower allocated must be such that these additional tasks do not compromise the tasks listed below.

- ICCA-005 monitor (jointly with the HSC) the run-down activities in order to ensure that all required spacecraft data are secured.
- ICCA-010 - moved to section 4.1 as ICCF-210 -
- ICCA-015 - moved to section 4.1 as ICCF-215 -
- ICCA-020 support the HSC helpdesk in helping archive users in the reduction of their data.
- ICCA-025 improve calibration files/data. Deliver updates to the HSC.
- ICCA-030 improve processing algorithms. Deliver updates to the HSC.
- ICCA-035 support validation of the data products generated with improved algorithms/calibration data.
- ICCA-040 process (as applicable) “specific” instrument modes (e.g. parallel and serendipity data) generated by their instrument. Deliver to the HSC.
- ICCA-045 support cross-calibration of their instrument with other instruments
- ICCA-050 maintain the necessary facilities and staff throughout the post-operations phase.
- ICCA-055 **Provide** documentation on calibration activities and instrument characterisation for the Instrument Handbooks and as legacy for future missions.

5. Herschel SCIENCE CENTRE (HSC): RESPONSIBILITIES AND DELEGATED TASKS

The tasks described here are carried out either by the Project Scientist Team (PST), led by the Project Scientist (PS), or, depending on the mission phase, by the HSC Development Team (HSCDT) led by the HSC Development Manager (HSCDM) or by the HSC Operations Team (HSCOT), led by the HSC Operations Manager (HSCOM). The PST will provide definitions of functional and operational tasks to be performed, the HSCDT or HSCOT will carry them out. The HSCDT will provide the infrastructure and tools necessary for the PST and HSCOT to carry out their respective tasks.

Just before launch, the HSCDT will cease to exist as an entity, partly being absorbed by the maintenance team. Likewise, the HSCOT will cease to exist as an entity in the post-operational phase, partly being absorbed by a reorganised PST. Details of these transitions will be defined after completion of the restructuring of SSD.

5.1 FUNCTIONAL REQUIREMENTS

5.1.1 Project Scientist Team (PST)

The PS/PST is responsible for the execution of the tasks listed below:

- | | |
|----------|---|
| FSCF-005 | act as the point-of-contact between the Herschel observatory and the outside world. |
| FSCF-010 | provide overall science coordination. |
| FSCF-015 | set up the HOTAC on behalf of D/SCI, and provide its terms of reference. |
| FSCF-020 | provide support to the HOTAC and the science community. This includes tasks such as: <ul style="list-style-type: none">– issue Call(s) for Proposals.– provide support to proposers re the tools and documentation required to complete and submit proposals; e.g. PGA or equivalent, proposal entry forms, instrument "time estimators" (<i>cf. ICCF-105</i>), observer's guide, instrument users manual, etc.– provide support to HOTAC re the tools required to assess and grade the observing proposals.– ensure availability of specialised instrument and data processing knowledge (e.g. by training, collocation, exchange of staff, participation in specific instrument activities, guaranteed time observations, etc.)– set up a central help-desk service to handle all requests from the community.– set up to accommodate to support on-site visitors. |

Note: Requests, which call upon specialised instrument knowledge not available at the HSC, will be relayed by the HSC to the relevant ICC. The ICC answers will be addressed to the HSC who will forward them to the initial requesters. This mechanism off-loads the ICCs from the burden of communicating with the external community. It is expected that such specialised requests will represent a small percentage of all queries addressed to the HSC.

- publish newsletters.
- provide statistics to [HOTAC](#) and ESA as required.
- provide support to authorised users in accessing their data and science-processing software required to process their observations.
- validate all scientific data by performing systematic quality control processing and checks on all data.
- provide support to the community re performing data processing.

FSCF-025 provide support to “key programmes” (e.g. large surveys) as required, including:

- support in the definition
- support in overall coordination
- support in processing programme inputs
- support in making results available to the general community (cf. note below)

*Note: The SIRD does not make any assumption as to the need (or otherwise) for specific tools which might be required to handle key programmes. It is assumed that if specific tools are required in addition to the "standard" HSC and ICC facilities and tools, the responsibility for their provision would be shared between the HSCDT and the ICCs. **This aspect must be addressed in the HSC and ICC SIPs.***

Note: Whether data from key programmes will be made available to the general community in a way different from other observations is a policy decision to be made by the scientific bodies that are coordinated by the Project Scientist, [and possibly ultimately by the SPC.](#)

FSCF-030 provide support to the ESA Public Relations (PR) effort.

FSCF-035 specify (in collaboration with the ICCs) the User Requirements for the Herschel Common Science System (HCSS). Maintain (i.e. update as required) the HCSS URD. Keep under Configuration Control.

Note: The HCSS groups all GS functionalities that are common to the science and instrument operations.

FSCF-040 monitor proper implementation of the requirements defined above by means of regular progress meetings, reviews, participation in software tests and user "trials".

Note: it is assumed that the PST will provide and execute an Acceptance Test Plan (ATP) and related procedures for HCSS releases of which the PST is a major user.

- FSCF-045 definition of the data and operational interfaces between the HSC and the science community and the HOTAC.
- FSCF-050 review and approve the ground segment science operations procedures.
- Note: The PS team ensures that the procedures, as defined by the HSCOT and the ICCs, maximise the science return.*
- FSCF-055 monitor instrument design and characterisation activities. Check against instrument performance requirements.
- FSCF-060 [Support the ICC in the definition of](#) the instruments calibration requirements.
- [FSCF-062](#) Set up and run the Herschel Calibration [Steering](#) Group ([HCalSG](#)).
- FSCF-065 coordinate (with the ICCs) the calibration programme [based on ground and space facilities](#) which will be necessary to support instrument calibrations pre- and post-launch.
- FSCF-070 monitor the instrument calibration activities (on ground).
- FSCF-075 [Support the ICC in the](#) preparation of the in-orbit instrument calibration programme. This requires:
- definition (with the ICCs) and maintenance of a consolidated Calibration Target List.
 - procurement and set up of various astronomical stars catalogues (e.g. IRAS catalogue, ISO catalogue, Hipparcos catalogue, Bright Stars catalogue, etc.)
- FSCF-080 define (jointly with the ICCs) the instruments in-orbit cross- calibration Plan.
- FSCF-085 [Support the ICC in the definition of](#) the Instrument in-orbit Performance Verification Plan.
- [FSCF-087](#) [Support the ICC in the definition of the Instrument Calibration Plan.](#)
- FSCF-090 review and approve the instrument flight operations procedures (nominal and contingency).

Note: this task is shared with the Herschel Project team and ESOC. ESOC ensures that the instrument flight procedures are safe and compatible with

the spacecraft procedures. The PST ensures that, as defined, the instrument flight procedures will maximise the science return.

FSCF-095 participation, as required, in pre-launch ground segment integration, validation tests and simulations. Support, as required, to ground segment reviews and project meetings.

FSCF-100 set up the HSC Operations Team (HSCOT).

*Note (TBC as part of the SSD re-organisation): The Project Scientist will nominate an HSC Operations Manager (HSCOM) who will set up and manage the HSCOT. It is expected that (some) members of the HSCDT will progressively join the HSCOT. It is further expected that both teams will co-exist for some time and that HSCDM and HSCOM will jointly share responsibility, under the PS supervision, for the execution of the various HSC tasks. **The HSC SIP shall address this aspect.***

FSCF-105 define, in collaboration with the ICCs, the data and facilities required at the HSC to support the post-operational phase including:

- archive contents (science data, calibration data, auxiliary and ancillary data, documentation, etc.).
- processing tools.
- archive access facilities.

Note: It is assumed that the H-GSAG (without MOC and Project representatives) will ensure monitoring of the post-operational phase activities.

FSCF-110 monitor the run-down activities to ensure that all spacecraft data required for the post-operational phase are collected and secured. Ensure necessary transfer of knowledge between the MOC, HSC and ICC teams.

5.1.2 HSC Development Team (HSCDT)

The HSCDM as leader of the HSCDT is responsible for the execution of the tasks listed below:

Note: The “management” of HCSS infrastructure and tools is likely to be carried out by the HSCOT (or, in a transition period, jointly by HSCDT and HSCOT). The two functions – provision and management— are not separated in this subsection in order not to lose the overview.

FSCF-120 establishment, jointly with the PST and ICCs, of the detailed list of HSC tasks and deliveries.

FSCF-125 provide input to the HSC Science Implementation Plan (SIP).

-
- FSCF-130 provide input to the overall HSC functional organisation.
- FSCF-135 establishment and maintenance of the overall HSC development schedule.
- FSCF-140 provide and manage the infrastructure (building, hardware, office space, communication equipment, etc.) as well as the support facilities (secretariat, clerical support, etc.) required, pre- and post-launch, to support the development, and later, mission operations work allocated to the HSC.
- Note: This includes accommodation and provision of the required logistical support to the Project Scientist and his team when they are located at the HSC.*
- Note: Part of the responsibility for providing certain infrastructure items may actually be taken over by the FSCOM.*
- FSCF-145 management of the HSC functional interfaces with the Project Team, PST, ICCs, and MOC.
- FSCF-150 manage development, provide and maintain the HCSS "infrastructure". This includes tasks such as:
- definition (jointly with the ICCs) of the Herschel Common Object Model (COM).
 - definition (jointly with the ICCs) of the interfaces between the data archive and the other HCSS sub-systems as well as interfaces between the HCSS and other external systems (e.g. the EGSE-ILTs).
 - procurement (and if required tailoring to Herschel's needs) of the (underlying) Archive Management System.
 - management of the HCSS infrastructure (pre- and post-launch). This includes all the necessary steps required to solve the issues of configuration control, data access rights, data security, archive integrity, etc.
- FSCF-152 provide (to MOC, in a format agreed with ESOC/Flight Dynamics) and "manage" the database of Solar System Objects.
- FSCF-155 manage development, provide and maintain a Proposal Handling (PH) System. This system shall include the facilities required for:
- reception, filing, sorting (if necessary) and checking of the observing proposals ("open time" proposals, "guaranteed time" proposals and key programmes).
 - generation and maintenance of the Proposal Data Base (PDB).
 - preliminary screening of proposals (technical feasibility, etc.) detection

and flagging of duplicate proposals.

Note: "checking" implies verifying completeness and syntax of proposals and verifying that the submitter is properly registered, "screening" implies a scientific/technical evaluation of the adequacy of selected sensitivity, requested observing time, target, observing mode, etc. Checking is an HSCOT task, screening is a PST task.

- generation of a proposal evaluation report for HOTAC.
- submission of the proposals to HOTAC.
- acceptance of the graded proposals from HOTAC.
- provision of feedback to the proposers.
- generation of proposals statistics.

FSCF-160 manage development, provide and maintain a Scientific Mission Planning System (MPS). This system shall include the facilities required for:

- selection from the Mission Data Base of a set of observations (may contain "guaranteed time" observations, "open time" observations, "key programme type" observations, "filler" observations, "fixed-time" observations, and ToOs).
- selection of "calibration" (origin ICCs) and/or "cross-calibration" observations as required.
- selection of instrument "engineering" observations requests as required (origin ICCs).
- selection of on-board memory load requests as required (origin ICCs.)
- handling of re-planning requests from the observers (failed observations) and/or the ICCs (failed calibrations, follow-up instrument diagnostic activities, etc.)
- scheduling, based on priority or any other scientific or technical considerations.
- making available a selected set of observations (or schedule) to the MOC.

Note 1: The selection involves a coordination process between all instruments in such a way that science output is maximised in accordance with a strategy formulated by the PST.

Note 2: "concatenated" observations are allowed, "linked" observations are not.

FSCF-165 provide and "manage" the Observation Data Base (ODB). This includes:

- define the structure and contents of the ODB according to HSCOT requirements.
- populate the ODB with "observations" using the Proposal Data Base (PDB) following the proposal selection process(es).
- set up and maintain the ODB throughout the mission, ensuring its

integrity at all times.

- update the ODB, as required, to take into account changes in mission parameters (e.g. instrument sensitivities, observing times, priorities, etc.) and/or spacecraft and/or instrument anomalies.
- update the ODB, as required, in order to flag executed observations, block/unblock observations, re-schedule (failed) observations (on PST request), etc.

Note: observations with one instrument mode might be blocked in the ODB, i.e. set to do_not_schedule in case of an anomaly with the instrument. Once the anomaly is corrected, the corresponding observation can be unblocked i.e. released for scheduling.

- provision of a "safe" editor, including audit trail (TBC by detailed user requirements on the HCSS) for updating selected entries into the ODB; the editor should support "global" editing and "undo" facilities.

Note: The ODB will be one of the data structures stored in the HCSS archive. It is expected that it will be set up and populated using standard facilities provided by the DBMS and HCSS infrastructure.

- FSCF-170 - deleted - replaced by FSCF-171.
- FSCF-171 manage development, provide and maintain the Common Uplink System (CUS). This system shall include the facilities required for:
- supporting the definition of instrument AOT
 - supporting the definition of engineering and calibration observations templates
- FSCF-175 definition (jointly with the ICCs and the MOC) of the data and operational interfaces between the HSC and the MOC and between the HSC and the ICCs.
- FSCF-180 ensure that the commonality standards defined jointly with the ICCs are adhered to in the S/W design and implementation of the HCSS sub-systems under the HSC responsibility.
- FSCF-185 provision, to the agreed standards, of all HSC-related documentation, including:
- operators and software users manuals (e.g. Proposal Handling, Mission Planning, data archive management, etc.).
 - HSC H/W and S/W Integration and Test Plans.
 - S/W test procedures and test results.
 - HSC-related ground segment operations procedures.
- FSCF-190 provide the necessary inputs, as required, to the Integration and Test Team (ITT) for the generation of the ground segment Integration and

Validation Plans as well as Simulation Plans.

- FSCF-195 participation, as required, in pre-launch ground segment integration, validation tests and simulations. Support, as required, to ground segment reviews and project meetings.
- FSCF-200 HSCDM attendance (as a permanent member) to the meetings of the H-GSAG
- FSCF-210 Provide and manage the Standard Product Generation system. This includes:
- the systematic and automatic generation of products for executed science observations from the observation raw data. This processing will be carried out by using IA modules provided by the ICCs, executed with default parameters.
 - the provision of persistent links between executed observation products, and associated uplink, auxiliary and quality data.
 - the qualification of each standard product with a description of the standard processing, calibration files and their versions used to generate them.
- FSCF-220 Provide and manage the On-Demand Processing system. This includes:
- to provide the astronomer with the capability to request the generation of scientific products with the latest data processing and calibration files versions.
 - to provide the possibility to customize the on-demand processing.
- FSCF-230 Provide and manage the Quality Control Processing system. This includes:
- the systematic and automatic generation of quality control data for each executed observation, which will include extracted information from the MOC operations reports and SCOS-2000 logs, and pre-defined information generated by the standard product generation processing.
 - to provide the capability for the instrument specialist to submit a quality control report for an observation.

5.2 OPERATIONAL REQUIREMENTS

The scope and/or frequency of some of the operational tasks listed below might change between the various phases of the Project. Some of the operational tasks could be carried out by the PST or by the HSCOT or (possibly) jointly. The allocation of responsibility between the two teams as indicated here, is, therefore, somewhat arbitrary. The details shall be elaborated in the relevant operations plans. In broad terms, the HSC operations will entail the following tasks.

5.2.1 Project Scientist Team (PST)

The PS/PST is responsible for the execution of the tasks listed below:

- FSCO-010 operate the Proposal Handling system. This includes:
- accept proposals from any "registered" location.
 - provide support to the proposers.
 - process proposals.
 - manage the Proposal Data Base.
 - provide feed-back to the proposers.
 - provide statistics to the HOTAC and ESA as required.
 - provide support to HOTAC.
- FSCO-012 Provide expert support, in collaboration with the ICCs, for the quality control of the observations.
- FSCO-015 provide science community support:
- operate the Central Help-desk.
 - support on-site visitors.
 - post information of general interest on the WWW or equivalent.
- FSCO-020 provide support to the ESA Public Relations (PR) effort.
- FSCO-025 release for access by the community the observations for which the "proprietary" period has expired.

5.2.2 HSC Operations Team (HSCOT)

It is assumed here that once the HSCDT has delivered the launch version of all S/W systems under its responsibility, maintenance of these systems (pre- and post-launch) is then carried out by the HSCOT. This is a somewhat arbitrary assumption. **The HSC SIP shall address this aspect.**

(with the caveat above) The HSCOM as leader of the HSCOT is responsible for the following tasks:

- FSCO-030 set up and train the operations team required to support the HSC activities pre- and post-launch.

Note: Training shall take place in accordance with an approved training plan. The Plan shall identify duration of each training activity and number of staff involved (trainers and trainees). Training external to the HSC, e.g. training involving MOC and/or ICCs, shall be identified in the Plan.

FSCO-035 provide trained HSCOT manpower, as required, to support pre-launch ground segment integration, validation tests and simulations.

FSCO-040 provide at the MOC, if required, the HSC operations staff necessary to support the Commissioning and Performance Verification phases.

Note: These specialists would be located at the MOC for the duration of these two phases. The necessary accommodations and logistical support would be provided by the MOC

FSCO-045 provide the trained HSCOT manpower required to support operations of the HSC in all phases of the mission.

FSCO-050 maintain the Proposal Handling System

FSCO-055 maintain and operate the HCSS data archive. This includes: (see FSCF-150):

- ensure that performance and availability requirements are met.
- ensure that all mission data are safely archived and made available to the authorised users.
- ensure that communications within the Herschel ground segment and between HSC and outside world are satisfactory. If necessary improve procedures and/or software.

FSCO-060 maintain and operate the Science Mission Planning System This includes:

- generation and maintenance of long term observing strategies according to PST requirements.
- generation and maintenance of up-to-date complete observing schedules through the end of the mission.
- generation of related statistical information as required.
- assist the ICCs in the planning of calibration and cross- calibration activities.
- assist the ICCs in the planning of specific instrument activities, e.g. "engineering" or "diagnostic" observations, instrument on-board software maintenance, etc.
- generation for each daily operations period of the observation and instrument command files required by the MOC's scheduling system.
- checking of the summary timeline generated by the MOC upon MOC scheduling.
- liaison with the MOC for re-iteration of the planning cycle (when required) e.g. problems with the summary timeline, handling of contingencies and ToOs.
- re-submission of an updated observation set (or schedule) to the MOC after re-iteration of the planning cycle.

FSCO-065 maintain and operate the Observation Data Base (ODB) i.e. update the ODB:

- to reflect the history of the previous observations.
- after reception of the proposals from a new "call".
- after PV (required "tuning" following assessment of in-flight performances).
- to accomodate concatenated observations.
- accomodate request for corrections/changes from the community.

- FSCO-067 Maintain and operate the Standard Product Generation system.
- FSCO-068 Maintain the On-Demand Processing system.
- FSCO-069 Maintain and operate the Quality Control Processing system. This includes:
- the monitoring of the automatic generation of the quality control data.
 - the human visual inspection of all observational data.
 - The co-ordination of the analysis of problematic observations (with PST, ICCs) and of the identification of failed observations.
- FSCO-070 set up a mechanism which allows to extract and summarise the status of all observations.
- Note: quick and easy access should be provided to the status of all observations (sheduled, not_scheduled, blocked, executed-when-, successful, failed, released, not_released, etc.).*
- FSCO-075 maintain the HSC. This includes the following tasks:
- maintain and upgrade as required the general HSC infrastructure.
 - maintain and upgrade as required the HSC software.
 - maintain and upgrade as required the HSC hardware. Carry out regular preventive H/W maintenance (this includes installation, if necessary, of new versions of operating systems).
 - perform routine S/W and data backups.
 - maintain the HSC operational documentation.
 - train (re-train) HSC staff as required.
 - operate the HSC hardware and software Configuration Control system. (maintain a central list of all HSC Software Problem Reports).
- FSCO-080 produce monthly HSC operations reports.
- FSCO-085 HSCOM attendance (as a permanent member) to the meetings of the H-GSAG

5.3 POST-OPERATIONS REQUIREMENTS

These activities concern essentially the tasks required to produce an archive of Herschel

data and data community. The tasks are shared by the (reorganised) PST and the ICCs. The ICC products, processed with the best calibration possible and make them available to the contributions are described in the corresponding chapter.

It must be noted that several of the tasks described here must be initiated before the end of the in-orbit operations.

The PS/(reorganised) PST is responsible for the execution of the tasks listed below:

FSCA-001 ensure overall management of the post-operations phase including:

- overall coordination and liaison.
- technical interfaces and schedule.
- overall configuration and quality control.
- protection of Archive against catastrophic loss.

FSCA-002 monitor run-down activities in order to ensure that:

- all required spacecraft data are secured.
- necessary MOC knowledge is transferred to the HSC.

FSCA-003 overall consolidation of the Archive including:

- consolidate Archive hardware (e.g. hardware upgrades, storage facilities, communication lines, etc.).
- consolidate Archive software.
- consolidate Archive contents.
- consolidate data processing tools.
- consolidate Archive access tools (emphasis on community access).
- consolidate documentation.

FSCA-004 support the "active" Archive phase, including:

- support to the community (helpdesk maintenance and upgrade).
- support on-site visitors .
- support for software and analysis methods.
- reprocessing of all observations.
- overall re-calibration and cross-calibration.
- definition and production of catalogues and atlases (TBC by the PS at the start of this phase, based on the data actually obtained).
- handling of specific requests (re-processing, re-calibration) (TBC by the PS at the start of this phase)
- monitoring of data quality.
- making available data, software, and (final) data products to the community through the HSC archive.

FSCA-005 transfer into the "Historical Archive" phase including:

- carry out overall Archive improvement programme (e.g. improve user's

interface, calibration and cross-calibration data, final "products", access speed, help facilities, etc.).

- publish "final" accuracy figures (e.g. relative/absolute flux calibrations, relative/absolute wavelength calibrations, instrumental calibrations, effects of pointing errors, etc.).
- Write and compile, in collaboration with the ICCs, all calibration information and the final documentation required for community support.
- perform "final" update of the documentation.
- transfer overall Archive system to its final destination.

6. PERFORMANCE AND AVAILABILITY REQUIREMENTS

This section does not record any performance requirements on the MOC. These will be contained in the MIRD (AD12).

6.1 GENERAL

PERF-000 The Ground Segment facilities (MOC, HSC and ICCs) shall be dimensioned in such a way that they can support without re-design an extension of at least one year of the in-orbit operations.

PERF-001 The Herschel Science Centre (HSC) shall be staffed on the basis of 8 hours/day, 5 days/week, as a minimum.

Note: Extended hours may be required during specific mission phases e.g. commissioning, PV, and extraordinary circumstances.

PERF-002 The Instrument Control Centres (ICCs) shall be staffed on the basis of 8 hours/day, 5 days/week, as a minimum.

Note: Extended hours may be required during specific mission phases e.g. commissioning, PV, and extraordinary circumstances.

PERF-003 The HSC and the ICCs shall be organised and staffed in such a way that the activities of mission preparation (e.g. for subsequent Calls for Proposals) and mission operations can proceed in parallel.

PERF-004 The overall availability figure for the ICC and HSC operational systems shall be 95 % minimum.

6.2 OBSERVATION PROPOSAL HANDLING

PERF-010 The Proposal Handling system shall be available 24 hours per day.

PERF-011 Maximum contiguous downtime of this function: 24 hours.

PERF-012 -deleted-

PERF-013 Proposal submitters shall be informed within 2 months (TBC by the PS when details of the proposal submission procedure are frozen for publication to the community) after proposal submission deadline of the HOTAC evaluation as to the status of their proposal

Note: Successful proposal submitters shall be informed within a reasonable time after the HOTAC meeting as to the validity (technical feasibility) of the proposal. During proposal submission interactive feed-

back on syntax errors shall be real-time.

PERF-014 The operational version of the Proposal Handling system shall be available to the PST at least 3 months prior to the first issue of a Call for Proposals.

PERF-015 The Proposal Handling system shall be able to handle a total of at least 4000 proposals, containing in average 50 observations.

Note: there should be no limitation to the number of observations that may be contained within a proposal.

Note: "handling" in this context is meant to imply syntax checking and storing of proposals.

PERF-016 The Proposal Handling system shall be able to handle at least 1000 proposals, containing in average 50 observations within 24 hours.

PERF-017 The Proposal Handling system shall be able to provide feedback in not more than 10 minutes (TBC in more detailed PST requirements on the proposal handling system) to a user having submitted a proposal on line. This first level of feedback is limited to acknowledging succesful proposal receipt and providing the result of a syntactic analysis of the proposal.

6.3 SCIENTIFIC MISSION PLANNING AND SCHEDULING

PERF-020 The Mission Planning and Scheduling facilities shall be able to generate individual daily schedules up to 3 weeks in advance.

PERF-021 The Mission Planning and Scheduling facilities shall be able to generate up to 8 individual daily schedules within 8 hours.

Note: This requirement applies to the H/W and S/W facilities needed, it is not a requirement on the Mission Planners.

PERF-022 -deleted-

PERF-023 Maximum contiguous down time for the Mission Planning and Scheduling functions: 24 hours.

PERF-024 The Mission Planning and Scheduling systems shall be available at least 3 months (TBC by the Project Scientist) prior to the issue of the first Call for Proposals.

6.4 OBSERVATIONS DATA BASE (ODB)

PERF-030 The Observation Data Base (ODB) shall not be unavailable (for whatever

reason) for more than 24 hours contiguously.

PERF-031 The ODB update facilities shall allow modification of up to 2000 observations in 1 hour.

Note: It is likely that the characteristics of many Herschel observations will need to be updated post-launch once spacecraft and instrument performances are measured in orbit.

6.5 CENTRAL HELP DESK

PERF-040 The Central Help Desk facility set up by the HSC shall be able to answer queries from the scientific community within 1 week on average (TBC by the PS in a "community support plan"). Maximum allowable answer time shall not exceed 3 weeks (ditto).

PERF-041 Herschel news of interest to the scientific community or the press shall be available on the World-Wide-Web (WWW) -or equivalent- with a maximum delay of 1 week (TBC by the PS in a "community support plan").

PERF-042 The Central Help Desk facility shall be in place at least 3 months (TBC by the PS in a "community support plan") prior to the issue of the first Call for Proposals.

6.6 Herschel NETWORK AND DATA ARCHIVE

*Note: The performance requirements in this chapter are only indicative of the type of global performances which might be expected of a system that has to capture, secure and distribute near-real-time and consolidated data to various users as well as to provide access to many different data items. The requirements below are (somewhat artificially) levied upon the data archive which is at the heart of the HCSS. Practically all communications between the various GS centres take place via object server(s) which form an interface layer around the data in this archive. Details can be found in RD10. It is to be noted that most performance requirements in RD10 are still TBD. **This section will need updating.***

PERF-050 The HCSS data archive and its services shall be available 24 hours a day.

PERF-051 HCSS maximum contiguous downtime: 24 hours.

PERF-052 MOC processing, the throughput of MOC/HCSS communication lines and HCSS processing shall guarantee that:

- in all mission phases ICC@ICC can access the consolidated HK TM not later than 20 minutes after the last bit of this data for the consolidation period has been received by the MOC.
- during Commissioning and PV phases ICC@ICC can access the

- consolidated Science TM not later than 2 hours after the last bit of this data for the consolidation period has been received by the MOC.
- during the routine phase ICC@ICC can access the consolidated Science TM not later than 32 hours after the last bit of this data for the consolidation period has been received by the MOC.

- PERF-053 The HCSS archive shall be able to support at least 250 interactive users logged on simultaneously.
- PERF-054 The HCSS archive shall allow several (authorised) users to read a data item in parallel.
- WRITE and UPDATE rights to a particular item shall only be granted to one user at a time.*
- PERF-055 The HCSS archive shall allow data deleted accidentally to be recovered up to a configurable period not less than 5 days after the deletion.
- PERF-056 All the data archived in the last 30 days, as well as the latest versions of the S/W and calibration files shall be ready to be delivered to authorised users within 5 minutes of a request. Other archived data shall be ready to be delivered within 30 minutes.
- Note: actual delivery time will depend on the size of the files to be downloaded, and on network performance and load. They are outside HSC control.*
- PERF-057 Maximum allowable response time per user category and per data-item: TBD
- PERF-058 -deleted-
- PERF-059a The HCSS shall support the storage of around a million observations with their associated data and products.
- PERF-059b The HCSS shall be able to ingest TM data at a higher rate than the on-board TM data generation and the instrument and additional test equipment.

6.7 SCIENTIFIC DATA PROCESSING

- PERF-060 All data required to fully process a given observation shall be available to the corresponding proposer within 1 week of the execution of his/her observation.
- PERF-060a MOC-provided data (command history, attitude- and orbit-related data, etc.) shall be available within 48 hours of the execution of the corresponding observation.

-
- PERF-060b At any time in the mission (including prior to launch) the latest, approved versions of the required instrument calibration files and scientific data processing software shall be available.
- PERF-061 - deleted -
- PERF-062 The Real-Time-Assessment (RTA) and Quick-Look Analysis (QLA) systems -generally used off-line in the ICCs- shall be capable of processing telemetry at least at the real time speed. Goal is several times the real time speed (e.g. 4 to 10 times).
- Note: This requirement covers Satellite Commissioning Phase and PV phase when RTA and QLA runs in near real-time in the MOC.*
- PERF-070 The HCSS shall process the TM associated with a 24 hours (nominal) observation window and produce the corresponding end-products (scientific, auxiliary data and quality data) in less than 2 hours.

7. PHASING AND ORGANISATION

The organisation of the project changes according to the various phases of implementation and operations. The various mission phases and responsibilities for the main sectors of the project are given as an overview in the table below:

Mission Phase	Highest authority/responsibility for Project Sector			
	Project/ Mission	Spacecraft Operations	Instrument Operations	Science
Development	PM	GSM	PM	PS
Launch and Early Orbit Phase (LEOP)	PM	FOD	N/A	PS
Commissioning	PM	MOM	MOM	PS
Performance Verification	SCI-S	MOM	MOM	PS
Routine Operations	SCI-S	SOM	SOM	PS
Post-operations	SCI-S	N/A	N/A	PS

- PM = Herschel Project Manager (SCI-PT)
 MD = Mission Director (= PM in LEOP phase)
 FOD = Flight Operations Director (ESOC)
 GSM = Ground Segment Manager (ESOC)
 SOM = Spacecraft Operations Manager (ESOC)
 SCI-S = Representative nominated by H/SCI-S
 PS = Project Scientist (reports to H/SCI-S)
 MOM = Mission Operations Manager (ESOC)
 Normally the GSM (TBC)

The responsibility and authority of all participants to the Herschel mission operations is defined in the Mission Operations Management Plan issued by ESOC.

In the routine phase the SOM has full authority for the safety and integrity of the mission and will be responsible for maximising the time during which scientific observations are made.

The PS reports to H/SCI-S. He is responsible for all scientific aspects of the mission.

The main activities and organisation for each phase are further described below.

7.1 DEVELOPMENT PHASE

7.1.1 Activities

This phase covers all activities up to the launch of the satellite (= spacecraft + scientific instruments). For the ICCs and the HSC, this includes design, implementation, integration and validation of their respective systems as well as verification of all interfaces, in particular interfaces with the MOC, and training of operations personnel. This phase culminates at the Flight Readiness Review which establishes Launch readiness. It formally ends at L - 8 hours (beginning of the LEOP phase).

7.1.2 Organisation

Fig 7.1 shows the top level organisation during the Development phase. Before the end of the Development phase (around L - 6 months -TBC in the MIP-) the build up of the Herschel Operations Team at the MOC will start.

This team will perform all spacecraft and instrument operations until the end of the orbital operations.

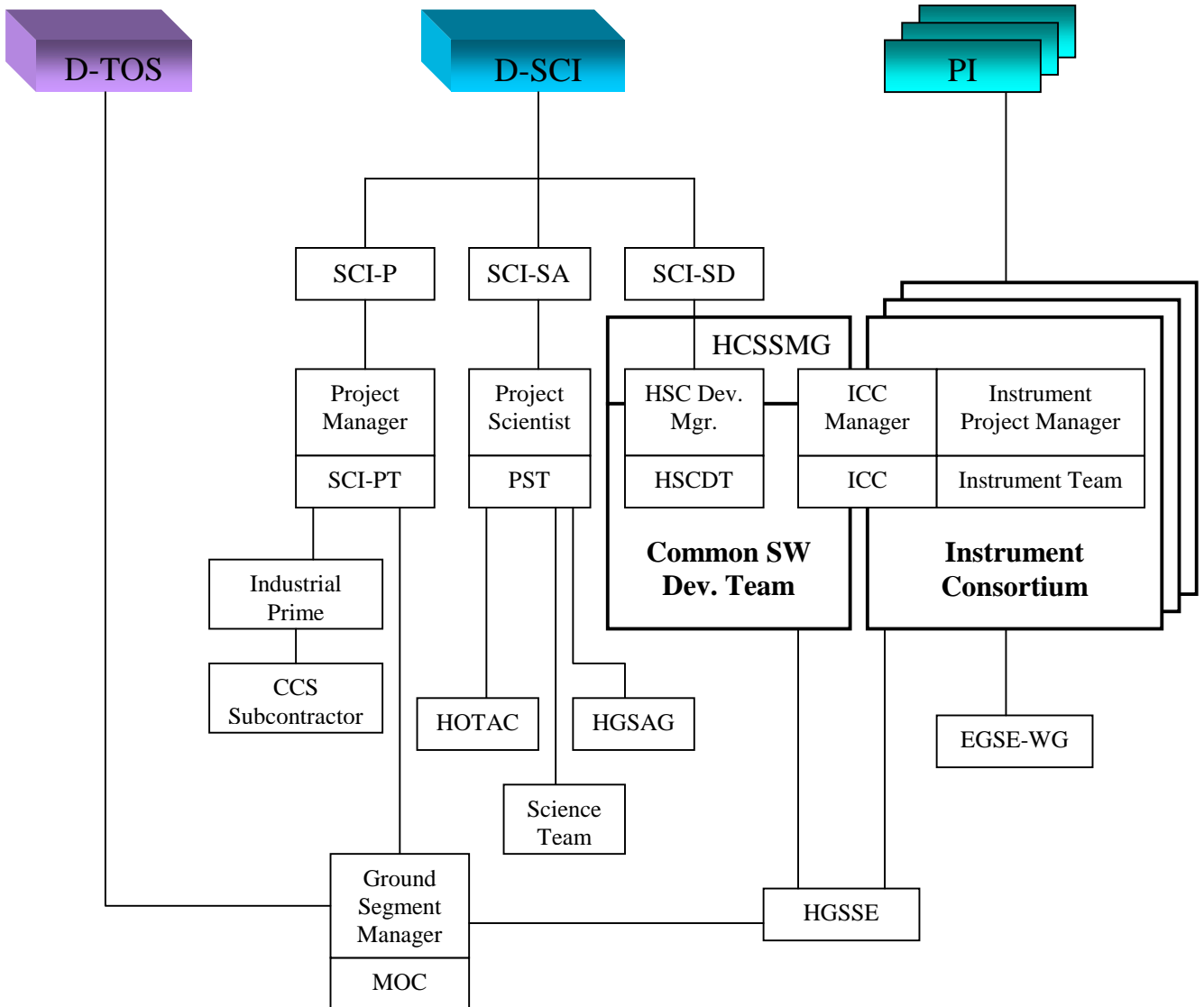

Fig. 7.1 ORGANISATION IN THE DEVELOPMENT PHASE

7.2. LAUNCH AND EARLY ORBIT (LEOP) PHASE

7.2.1 Activities

The LEOP is the first operational phase in the Herschel mission.

The LEOP phase is conducted from the Main Control Room in ESOC according to the practices laid down in the ESTRACK Operations Manual (EOM). Mission rules and detailed LEOP activities are defined in the Herschel Flight Operations Plan (FOP).

During LEOP, checkout of essential spacecraft functions will be carried out. The scientific instruments are switched off.

Nominally, LEOP duration will be less than 10 days. At the end of the LEOP, the satellite shall be in a condition where payload and instrument-related operations can begin.

During LEOP telemetry will be acquired and archived. If required the ICC Instrument Stations running RTA and QLA will be on-line in listen-in mode in the MOCs Instrument Support Area although no scientific data will be available.

7.2.2 Organisation

Fig 7.2 shows the overall top level organisation during the LEOP phase.

LEOP is an ESOC responsibility. It is conducted by the Herschel Flight Control Team (FCT) under the authority of the Flight Operations Director, appointed by D/TOS. Overall supervision is ensured by the Herschel/Planck Project Manager acting as Mission Director.

The FCT is made up of several different groups, Herschel dedicated groups, and non-Herschel dedicated support groups manning the various Operations Control Centre (OCC) support area(s)/rooms.

The FCT will be run on a twenty four hour shift basis for at least the first 10 days of LEOP.

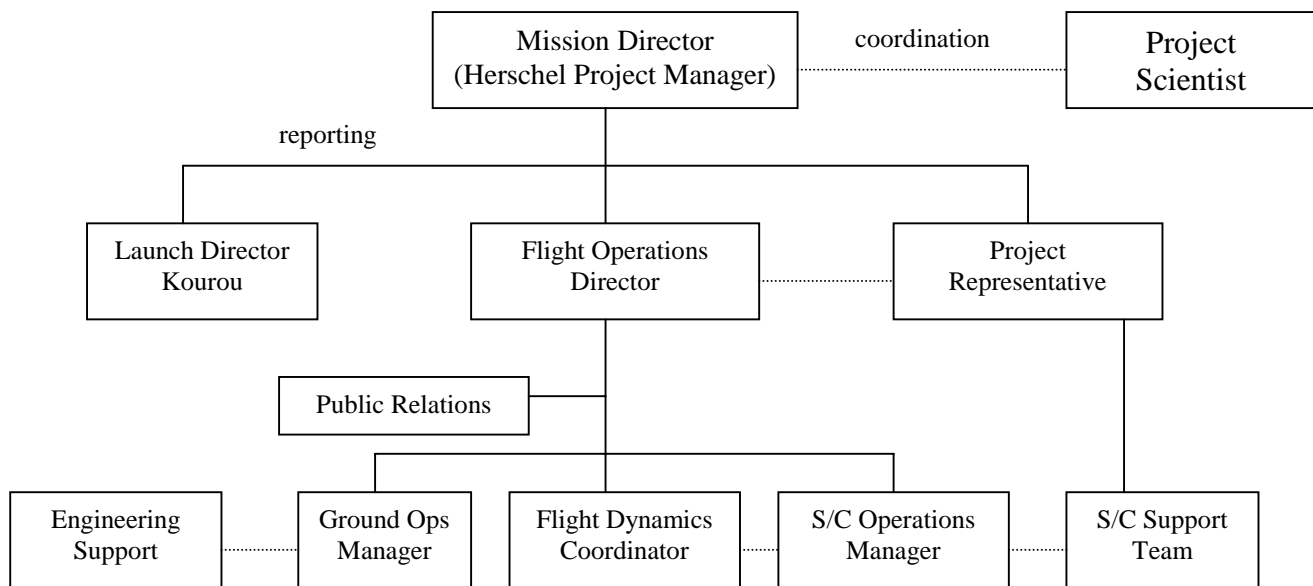

Fig. 7-2: Organisation during LEOP Phase

7.3. COMMISSIONING PHASE

7.3.1 Activities

At the end of the LEOP phase, spacecraft and instrument control will be transferred to the Herschel Dedicated Control Room (DCR).

In addition, ICC operations staff, located in the Instrument Support Area in the MOC (the ICC@MOC), will monitor execution of their instrument activities using the hardware and software (Instrument Stations and RTA and QLA software) which they have used during instrument level tests and AIV operations.

ICC staff at the ICC site (ICC@ICC) will receive –via the ICC@MOC- the TM data acquired by the MOC and provide support to the ICC@MOC as required. Beyond the provision of internet connectivity ("a socket in the wall"), management of the communication link (hardware and operational set up) between the two ICCs is the sole responsibility of the ICCs.

During this phase the checkout of the spacecraft subsystems will be completed (as necessary) if completion was not achieved at the end of the LEOP phase. The scientific instruments will then be turned on and checked out. Check out will be carried out by repeating a subset of the Integrated System Test (IST).

The next activities will be dedicated to satellite commissioning.

The purpose is to assess in-orbit performance of the satellite since this will determine to a large extent how the routine operations will be carried out.

The following major activities are foreseen:

- assessment of Herschel pointing performances: This implies determination of Attitude Pointing Error (APE), Attitude Pointing Drift (APD), Relative Pointing Error (RPE) and Absolute Measurement Accuracy (AMA);
- assessment of stray-light and telescope performances: This includes measurement of Self Emission, Off-Axis Rejection, Stray-light induced by a bright source in the field of view, as well as determination of the Point Spread Function and Focal Plane Geometry Calibration.¹

The sequence of operations, their duration and the corresponding detailed activities will be defined in the Herschel Flight Operations Plan (FOP) issued by ESOC and the Satellite Commissioning Plan (SCP) issued by the Herschel/Planck Project.

Telemetry will be acquired and archived.

¹ Some of these activities might have to be delayed to later phases.

7.3.2 Organisation

Overall responsibility for this phase lies with the Project supported as required by Industry, ESOC and the ICC operations staff. Fig. 7.3 shows the overall organisation.

Operations will be under the responsibility of the MOM.

The FCT will have the responsibility to carry out the satellite commissioning activities as described in the FOP and SCP. Processing of the relevant data will provide the necessary performance information. Project, Industry, ESOC and ICC staff will assess this information and determine pointing and telescope performances as well as initial instrument operability. It is anticipated that the "Project Scientist" Team will be involved in the activities covering straylight measurement and telescope performance evaluation. In this case the relevant PST members will be located at the MOC.

The ICC staff at the MOC will report to the MOM. As required, the ICC staff will liaise with and obtain support from the ICC personnel which has remained at the ICC. Participation of the HSC in this phase is TBD.

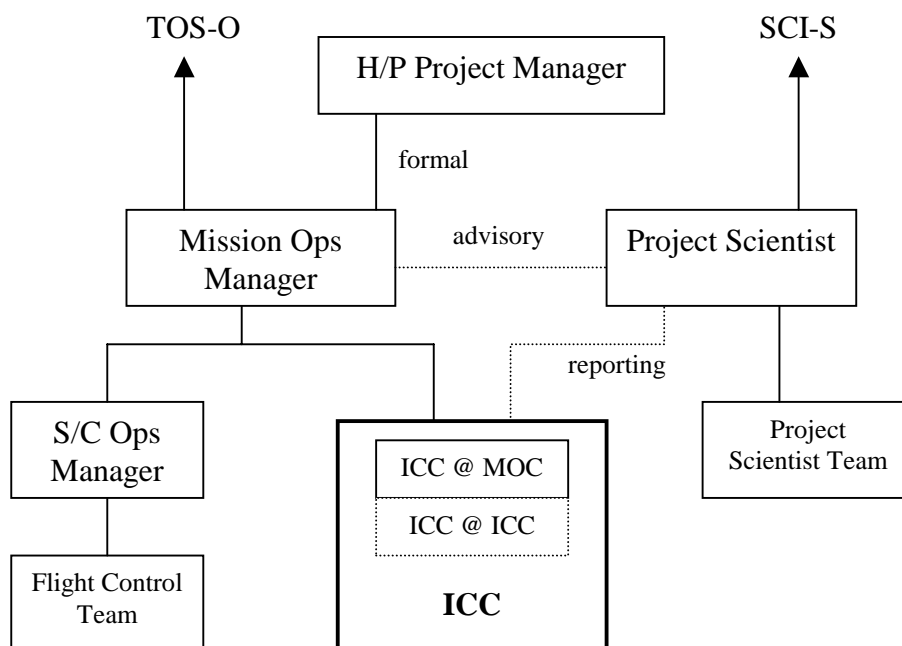

Fig. 7-3: Organisation during Commissioning Phase

7.4. PERFORMANCE VERIFICATION PHASE (PV PHASE)

7.4.1 Activities

During this phase, calibrations of the scientific instruments will be made and scientific measurements on celestial sources will be started. The Commissioning of the overall ground segment that started in the previous phases will be completed.

The following major activities are planned:

- instrument "core" calibration;
- AOT's verification: functional and scientific aspects;
- Full observatory verification i.e. verifying that facilities and teams are ready to support the routine scientific observations.

The sequence of operations, their duration and the corresponding detailed activities will be defined in the Herschel Flight Operations Plan (FOP) and in the Performance Verification Plan.

In the PV phase the focus of ICC operations will move from the MOC to the ICC location. From there ICC staff will monitor the activities of their instrument using the data as ingested in the HCSS through the standard MOC-HSC-HCSS route. Instrument data will be analysed using ICC systems (IA, TA, RTA and QLA in replay mode) to determine calibration parameters. From here also when needed new calibrations and/or tests with relevant scheduling information will be inserted in the observation data base for execution. In contingency situations -when needed- (near real time) activities will be conducted from the ICC@MOC in the same fashion as during check out.

The HSC will be fully involved in this phase. Co-location of HSC personnel at the MOC is however not foreseen.

Starting with this phase, all operations should be pre-planned.

At the end of the Performance Verification phase the S/C, payload and Ground Segment will be considered operational.

7.4.2 Organisation

The organisation during the PV phase will be similar to the organisation during the commissioning phase.

Fig. 7.4 shows the overall organisation in this phase.

Operations are under the responsibility of the MOM.

The HSC functional tasks are carried out by the HSCOT. Both PST and HSCOT are located at the HSC. The external science community is not involved.

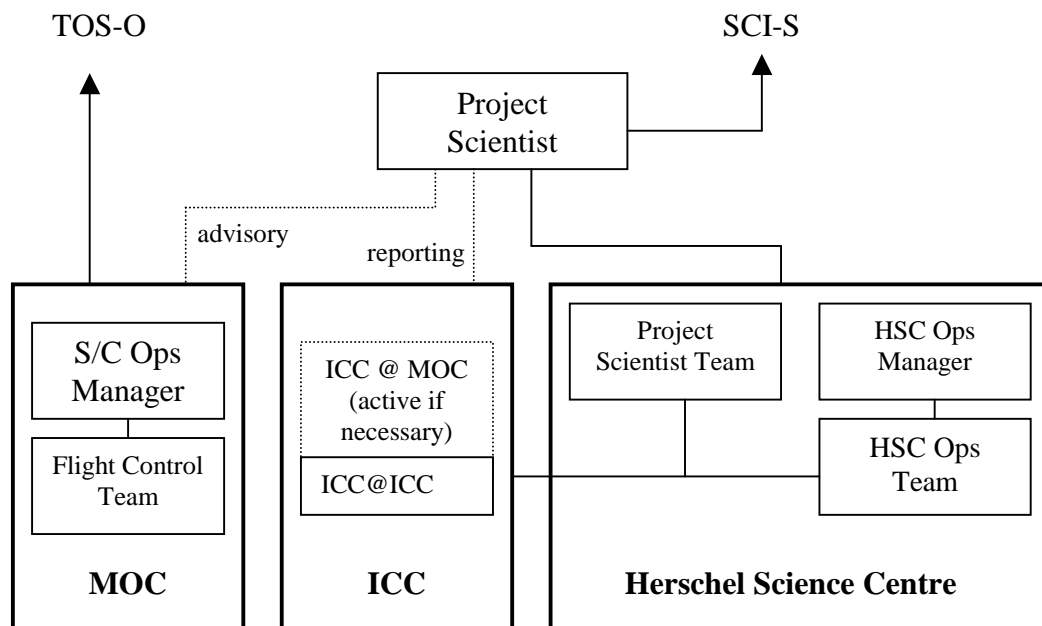

Fig. 7-4: Organisation during Performance Verification Phase

7.5. ROUTINE OPERATIONS PHASE

7.5.1 Activities

This phase is the main data gathering phase in Herschel's lifetime and, during this period, surveys, "guaranteed" observations and "open-time" observations will be made.

During the Routine Operations phase all activities are pre-planned. The observation schedule will normally be executed autonomously from telecommands stored on-board. The command schedule will be up-linked daily from the ground station.

7.5.2 Organisation

Fig. 7.5 shows the overall organisation in this phase.

All spacecraft and instrument operations are carried out by the SOM and his/her team. ICC manpower is no longer required at the MOC.

The Instrument Support Area in the MOC is no longer in daily use but is not decommissioned. In case of unforeseen problems or contingencies ICC staff may be recalled at the MOC on short notice.

The MOM function is terminated and day-to-day operational responsibility is transferred to the SOM.

The ICCs and the HSC enter their steady mode of operations. The external scientific community is involved.

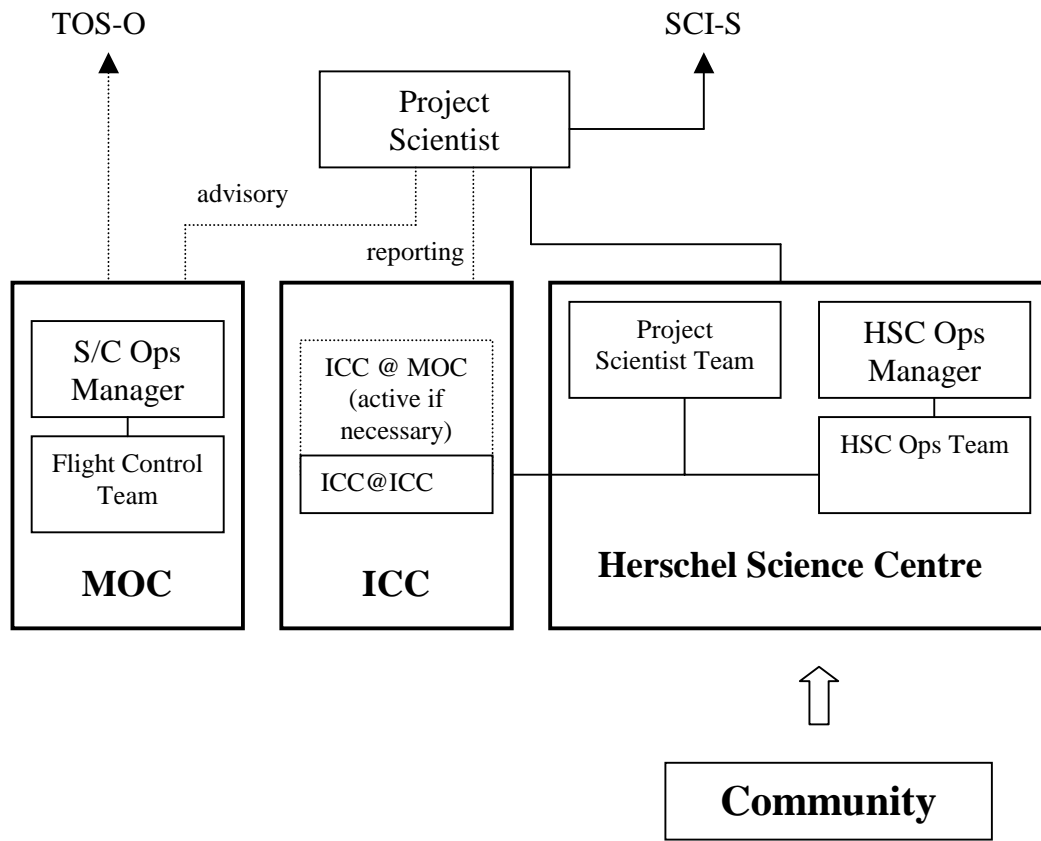

Fig. 7-5: Organisation during Routine Phase

7.6. POST-OPERATIONAL PHASE

7.6.1 Activities

The activities carried out in this phase are as described in chapter 2.4.7. The HSCOT's activities are limited to the management of the HCSS archive. MOC-related activities are terminated at the end of the run-down phase. The bulk of the work is carried out by the PST and the ICCs.

7.6.2 Organisation

Until the end of the run-down phase the organisation is as shown in Fig. 7.5. The SOMs team is a reduced team (mainly FD specialists and maintenance staff). The HSCOT is also reduced since Proposal Handling and Mission Planning are no longer required. At the end of this phase the SOM and his team are no longer involved. Involvement of the HSCOM in the post-operational phase is TBD.

8. PRODUCT ASSURANCE and QUALITY ASSURANCE REQUIREMENTS

8.1 GENERAL

These general requirements are applicable to all the entities which contribute to the preparation and execution of the Herschel operations.

PAQA-001 During all phases of the Herschel mission implementation (i.e. design, development, integration and test of the total ground segment both hardware and software) each contributor shall carry out a Product Assurance/Quality Assurance (PA/QA) activity.

The purpose of the PA/QA activity is two-fold:

- *It ensures during each phase conformity of the outputs with the inputs from a previous phase. It ensures traceability from requirements to design for both hardware and software elements.*
- *It ensures adherence to the standards established for the Herschel mission. It ensures that all hardware and software elements of the ground segment implementation will comply with all mission requirements.*

PAQA-002 The PA/QA activity shall also be exercised throughout the operations phase of the mission to ensure that all satellite operations are carried out in accordance with agreed flight procedures, and that all modifications requested by any authorised party will be controlled by a formal Change Control (CC) procedure.

PAQA-003 - deleted -

PAQA-004 The PA/QA aspects shall be addressed at each review of the various components (i.e. HSC, MOC, ICCs) of the Ground Segment as well as during the reviews of the entire GS and the Mission Level reviews.

PAQA-005 The HSC and the ICCs shall (as part of the PA/QA function) carry out a risk assessment of their overall activities. Practical risk mitigation measures shall be identified and implemented.

Note: Status shall be reported as part of regular reporting. This aspect shall be addressed on the occasion of the relevant reviews.

8.2 DOCUMENTATION

PAQA-010 Documentation shall be structured in a specification tree and a corresponding plan tree. The documents shall be referenced in accordance with an identification procedure consistent with the trees.

PAQA-010a The trees shall be structured in such a way that the scope and applicability of each document as well as the documents inter-relationships are easily seen. Each top level tree shall hold on a single A4 page.

PAQA-010b Requirement specifications, design specifications, test specifications, interface control documents and user manuals shall belong to the specification tree.

PAQA-010c Implementation plans and procedures, test plans and procedures, and operations plans and procedures shall belong to the plan tree with the corresponding execution reports.

PAQA-011 Software documentation shall conform to the ECSS Standards (AD7 and AD8)

Note: The ECSS Standards must be tailored to each individual project's need. The HSC has carried out this tailoring process for its contribution to the HCSS. It is assumed that the ICC-provided HCSS elements will conform to the HSC-tailored standards. The SIRD does not put any specific "tailoring" requirement on other elements of the ICCs.

PAQA-012 The Herschel Ground Segment documentation which must be accessible to all participants in the programme shall conform to the electronic standards defined for the Herschel/Planck Programme.

Note: These standards must be defined and agreed jointly by the HSC, ICCs, MOC and Herschel/Planck Project.

8.3 TEST REQUIREMENTS

These test requirements are applicable to the entities (in particular ICCs and HSC) which contribute to the Herschel Science Operations. Test requirements specific to the MOC are addressed in the MIRD (AD12)

PAQA-020 All operational science functions of the Ground Segment shall be tested and validated before launch.

PAQA-021 - deleted -

PAQA-022 Subsystem and system tests shall be conducted according to approved test plans and test reports shall be issued.

- PAQA-023 The adequacy of the science operations procedures shall be determined by means of realistic simulators covering at least:
- execution of all nominal procedures;
 - execution of all foreseen contingency procedures.
- PAQA-024 The ICCs and the HSC shall be included, as required, in the Satellite Verification Tests (SVTs) in order to verify their interfaces with the satellite and the other elements of the ground segment.
- PAQA-025 The ICCs and the HSC shall be included in the End-to-End Tests (EEs) which validate proper operations of the entire space- ground segment system.
- PAQA-026 The ICCs and the HSC shall be included in the overall simulation programme which determines the adequacy of operations procedures and training of mission controllers, computer operators and all other operations staff

8.4 CONFIGURATION CONTROL

8.4.1 Hardware Configuration Control

- PAQA-030 The ICC and HSC H/W configurations (Computers, Work-Stations, Peripherals, LANs, communication equipment, etc.) shall be maintained under Configuration Control according to the general guidelines in RD18.

8.4.2 Software Management and Configuration Control

- PAQA-031 All HCSS S/W elements, documentation and data items shall be delivered for integration and archiving in accordance to the HCSS Configuration Control System.
- PAQA-032a The HCSS implementation shall be carried out in accordance to a (common) Software Project Management Plan (SPMP) to be produced jointly by the ICCs and the HSC.
- PAQA-032b The implementation of the other (i.e. non-HCSS) ICC S /W elements shall be carried out in accordance to an ICC Software Project Management Plan (SPMP) to be produced by each ICC.

8.5 SOFTWARE QUALITY ASSURANCE

- PAQA-033a All HCSS S/W elements shall be produced in accordance to a (common) Software Quality Assurance Plan (SQAP) to be produced jointly by the ICCs and the HSC.

PAQA-033b The implementation of the other (i.e. non-HCSS) ICC S/W elements shall be carried out in accordance to an ICC Software Quality Assurance Plan (SQAP) to be produced by each ICC.

9. MANAGEMENT REQUIREMENTS

9.1 TOP LEVEL RESPONSIBILITIES

The Herschel Ground Segment architecture is a decentralised architecture. The allocation of responsibilities for the monitoring, management, coordination and implementation of the tasks specified in this document reflects this decentralised structure.

MNGT-001 For each of the Instrument Control Centres (ICCs) -one per Instrument- there shall be an ICC Manager with overall responsibility for the timely execution of all ICC-related tasks specified in this document.

MNGT-002 The Project Scientist (PS), who has ultimate responsibility for all HSC-related matters, shall ensure timely delivery of all the HSC deliverables and timely execution of all HSC tasks specified in this document.

Note: in practice actual responsibility will be assumed by the HSCDM, and HSCOM under PS supervision.

MNGT-003 The Herschel Ground Segment Advisory Group (F-GSAG) shall be responsible for the monitoring of the ICCs, HSC and MOC activities in order to verify that the tasks specified in this document are carried out according to specification and in agreement with the overall Ground Segment development schedule.

MNGT-004 The Integration and Test Team (ITT), under the authority of an ITT Manager, shall be responsible for the overall ground segment Integration and the definition and execution of the system-level tests defined in chapter 8.

9.2 PLANNING REQUIREMENTS

MNGT-010 In response to the requirements specified in this document each ICC manager and the Project Scientist shall issue a Science Implementation Plan (SIP) covering the tasks under their responsibility. After approval/agreement the SIPs shall serve for monitoring progress of the tasks identified therein.

MNGT-011 The SIPs shall respond to the requirements specified in this document. In particular each SIP:

MNGT-011a shall contain a Project Management Plan;

MNGT-011b shall contain a description of the related science operations concept and baseline design. It shall be as detailed as needed to allow a committing schedule, and a well-established work package breakdown structure;

- MNGT-011c shall contain the definition of the work packages with the corresponding inputs, deliverable items, tasks specifically excluded, progress measurement points and start and completion criteria.
- MNGT-011d shall cover for each work package, the identification of the cost driving parameters and the corresponding estimates of resources spread over time (manpower, computers and other investment and running expenditure).
- MNGT-011e shall define the schedule for the complete set of work packages supported by the corresponding schedule planning.
- MNGT-011f shall contain the documentation trees and the corresponding identification.
- MNGT-012 Any change in the contents of a SIP might imply changes in cost, schedule and/or performance of the corresponding science function; therefore any modification to the SIP, or tasks, or baseline identified therein shall be formally approved by ESA:

Baseline: the Herschel/Planck Project Manager approves the HSC SIP
the Herschel Project Scientist approves the ICC SIPs.

9.3 REPORTING REQUIREMENTS

- MNGT-020 The ICC managers belong to the corresponding PI-Institutes. They report to the PI (either directly or via the Instrument Project Manager).
- MNGT-021 The HSCDM and the HSCOM are members of the Space Science Department. They report to the PS. The PS reports to H/SCI-SA.
- MNGT-022 The ICC managers, the HSCDM and the HSCOM will attend the meetings of the F-GSAG (of which they are permanent members) in order to provide progress reporting.
- MNGT-023 The ICC managers, the HSCDM and the HSCOM will, as needed, attend the Herschel meetings and reviews, management meetings and delegate body meetings.
- MNGT-024 The SIPs shall define in detail the reporting mechanisms which shall include, as a minimum, quarterly (TBC) management information reports. These reports should be brief and include the following information:
- MNGT-024a brief summary of the progress achieved since the previous reporting period.
- MNGT-024b concise description of the main problem areas, their criticality and anticipated impacts (e.g. delays in the schedule or non conformance with the requirements).

-
- MNGT-024c status of the technical design, of proposed solutions to the problem areas and of engineering, product assurance and testing activities.
- MNGT-024d per Work Package the manpower usage showing actual versus planned and estimation at completion.
- MNGT-024e overall manpower usage chart.
- MNGT-024f update of the overall schedule with latest prediction of the completion dates of the identified milestones.
- MNGT-024g a list of relevant (e.g. ICC-related and HSC-related) action items and their status.

*Note: There is **no** requirement to produce any financial information containing actual expenditure related to work packages for manpower usage, infrastructure, investment, etc. HSC-related cost information will be provided to the Herschel/Planck Project Manager according to ESA standard procedures.*

- MNGT-025 The SIPs shall identify the technical documents to be produced for the implementation of the tasks specified in the SIRD; it shall also define the review procedure and the approval authority for the various documents.